

What is PCF8574-Nx

PCF8574-Nx is a kit to interface 8-bit digital IO chip to NXT. It contains all the basic parts needed along with general-purpose prototyping area on the PCB. This kit can be used to design any custom sensor or IO device with NXT. Following sections provide basic assembly instructions for this Kit.

PCF8574-Nx Feature List

- Uses NXT compatible I2C protocol for communications.
- All needed basic components included.
- Position for second NXT compatible socket that lets you connect the multiple boards to same sensor port.

Connections

Can be connected to any four ports of NXT by using standard NXT cables.

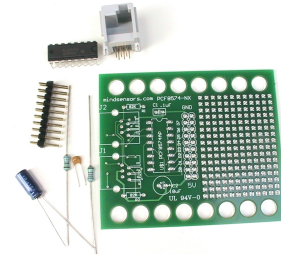

Tools you will need

All the electronic components needed for assembly are included. To assemble these components, you will need a soldering iron, solder, pliers, and wire cutter to cut the resistor and capacitor wires.

Assembly

Connect all the components as shown on the PCB silkscreen. You can connect NXT style socket either to J1 or J2. You can use the second jack to daisy chain the boards. That way, you can connect more than one sensor to single NXT port. If you plan to do that, ensure to use resistors R1 and R2 only on one board.

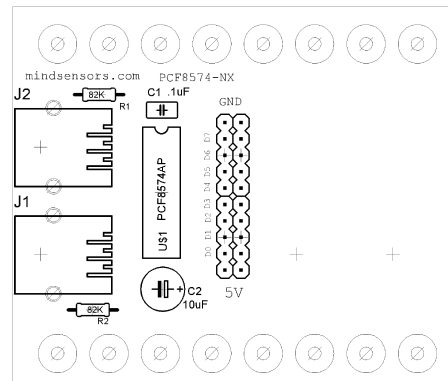

Also ensure to select the correct address by shorting the PCB jumpers A0 A1 A2 at the bottom of the board either on the lower side (logic low) or the upper side (logic Hi). e.g. Shorting A0, A1, A2 all to logic low will set the I2C address of 0x40. For more details on address selection refer to the PCF8574 datasheets.

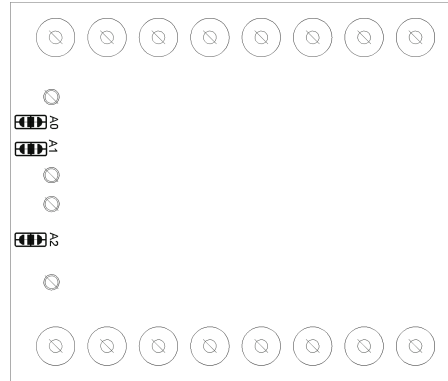

Programming Techniques for reading in I2C mode

NXT-G:

You can use the PCF8574-Nx with PCF8574-NX sensor block. You can download this block from 'Download' section of mindsensors.com website. (This requires Dynamic block update patch installed on your NXT-G).



NOTE

Ensure to use LEGO firmware 1.05 on NXT while using NXT-G blocks.

RobotC:

You can use example program in C and robotC compiler to use PCF8574-Nx on your NXT robot.

NBC:

You can use example program in NBC and NBC compiler to use PCF8574-Nx on your NXT robot.

Robolab:

You can use example program and drivers Vi in Robolab 2.9 compiler to use PCF8574-Nx on your NXT robot.

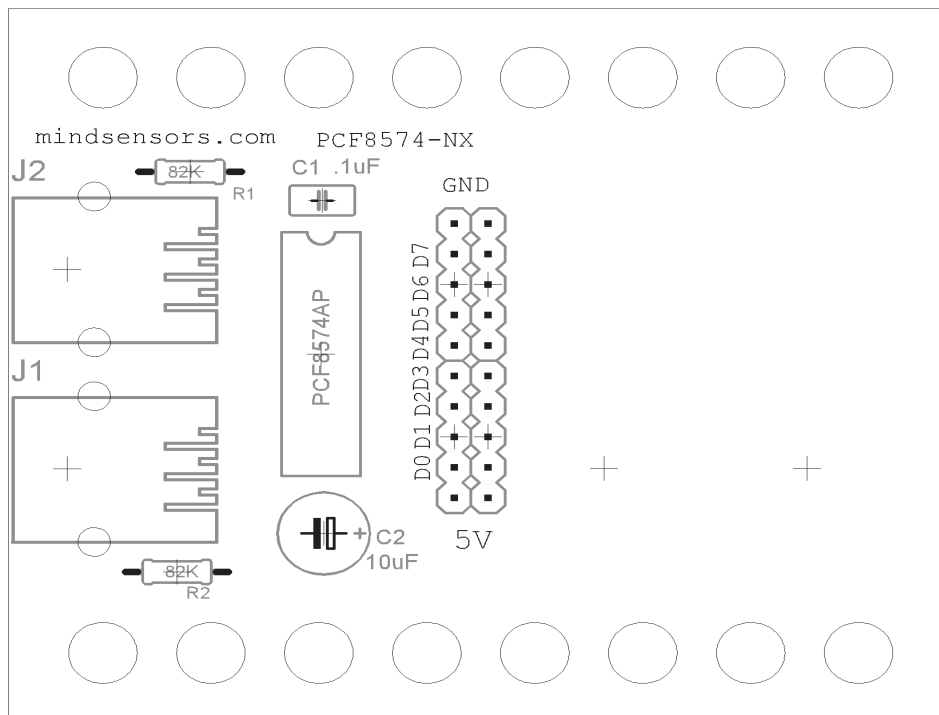

Figure 1 PCB Silk Screen

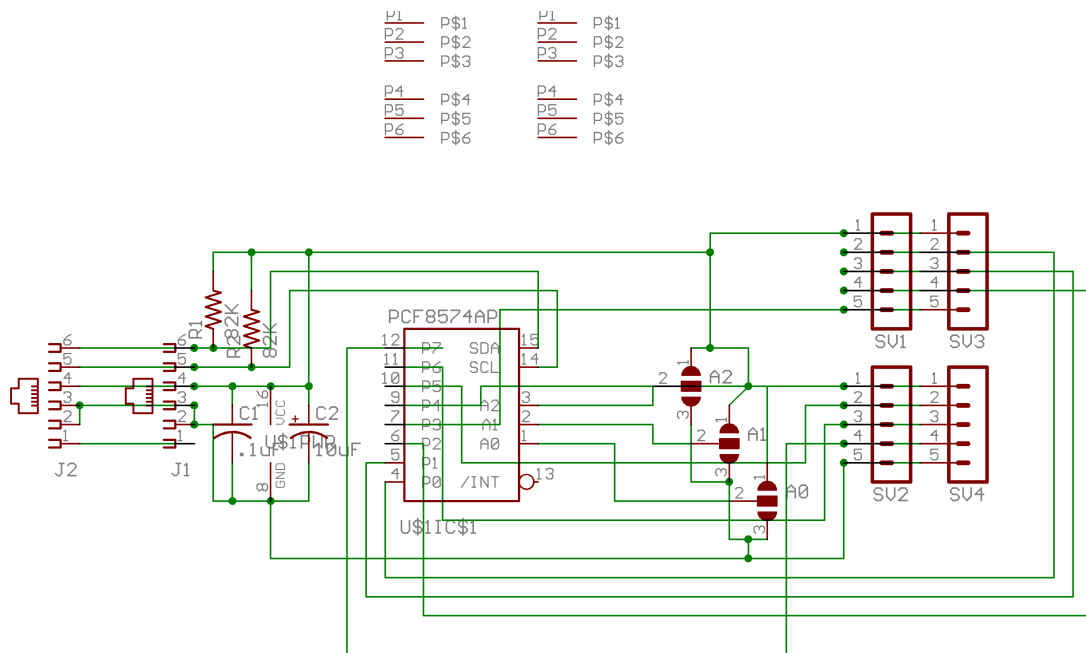

Figure 2 Schematic Diagram

Frequently Asked Questions (FAQ)

How do I identify a resistor?

Each color band on a resistor is associated with a number as follows:

Color	Number
Black	0
Brown	1
Red	2
Orange	3
Yellow	4
Green	5
Blue	6
Purple	7
Gray	8
White	9

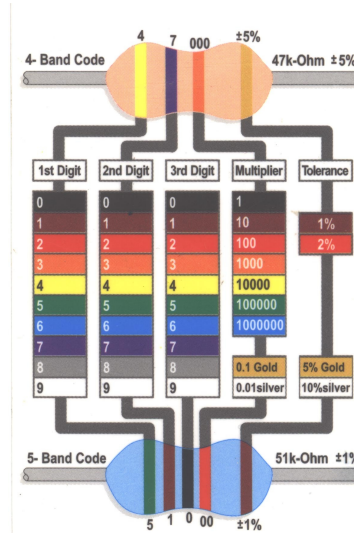

On a 4-band resistor, third band is the multiplier band. The adjacent picture shows how to read the bands on the resistor.

How do I read the pins on an IC?

Pin no. 1 on the IC is usually marked with an engraved dot. Hold the IC such that the pins are facing away from you, and number the pins anticlockwise, beginning at pin with the dot.

How do I identify a diode and it's direction?

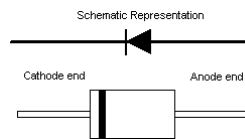

Diodes normally have glassy casing, and are marked with a band on one end.

The band end is the 'cathode' and the other end is the 'anode'. Within the diode, the current flows from anode to

cathode.

On the Schematic, the cathode end is represented as the tip of the arrow.

How do I identify LED polarity?

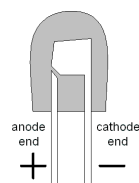

Hold the LED against the light, and when you look at the metal elements inside, you will notice that one half is bigger than the other and looks like a flag, this is the 'cathode' (or negative) end of the LED.

How do I connect the LEDs?

Hold your LED against the light and inside, the cathode end inside (as shown in above picture) should match up with the flat side on PC board marking (silkscreen).

How do I distinguish C1 and C2?

C2 is the larger capacitor, whereas C1 is the smaller capacitor.

Assembly tips

- The pins can be bent suitably to attach on the PCB.
- While assembling, solder the components with many pins first, (such as IC) and then solder components with lesser number of pins. Finally solder the connecting wires.

Further reading

How to read a diode:

<http://www.americamicrosemi.com/tutorials/diode.htm>

How to read resistor

<http://www.aikenamps.com/ResistorColorCode.htm>

http://www.eidusa.com/Electronics_Resistors.htm

Tips on soldering

http://library.thinkquest.org/2784/inspire/soldering_hints.html

How to read schematics

<http://www.learn-c.com/schemat.htm>

Books

Beginners Guide to Reading Schematics, by Robert J. Traister, Anna L. Lisk.

Warnings

- Wear Eye protection gear while assembling the kit.
- Soldering iron is hot, and be careful while handling it.
- While soldering, do not heat components any longer than 10 seconds, it may damage the components.
- The fumes generated while soldering may be harmful. Work in a well ventilated area and do not breathe the fumes.
- The soldering metal may contain lead. So wash your hands thoroughly with soap after handling such materials.
- When fully assembled, test with a 9 volts non-RCX power before attaching to RCX.
- Improper assembly may damage kit components.