

**COGNEX**

---

# In-Sight<sup>®</sup> 7000 Series Vision System

Installation Manual

**IN-SIGHT**  
Vision Systems



# Legal Notices

The software described in this document is furnished under license, and may be used or copied only in accordance with the terms of such license and with the inclusion of the copyright notice shown on this page. Neither the software, this document, nor any copies thereof may be provided to, or otherwise made available to, anyone other than the licensee. Title to, and ownership of, this software remains with Cognex Corporation or its licensor. Cognex Corporation assumes no responsibility for the use or reliability of its software on equipment that is not supplied by Cognex Corporation. Cognex Corporation makes no warranties, either express or implied, regarding the described software, its merchantability, non-infringement or its fitness for any particular purpose.

The information in this document is subject to change without notice and should not be construed as a commitment by Cognex Corporation. Cognex Corporation is not responsible for any errors that may be present in either this document or the associated software.

Companies, names, and data used in examples herein are fictitious unless otherwise noted. No part of this document may be reproduced or transmitted in any form or by any means, electronic or mechanical, for any purpose, nor transferred to any other media or language without the written permission of Cognex Corporation.

Cognex P/N 597-0138-01 Rev. C

Copyright © 2011 - 2013 Cognex Corporation. All Rights Reserved.

Portions of the hardware and software provided by Cognex may be covered by one or more of the U.S. and foreign patents listed below as well as pending U.S. and foreign patents. Such pending U.S. and foreign patents issued after the date of this document are listed on the Cognex web site at: <http://www.cognex.com/patents>.

---

5481712, 5742037, 5751853, 5845007, 5909504, 5943441, 5949905, 5960125, 5978080, 5978081, 6005978, 6137893, 6141033, 6154567, 6215915, 6301396, 6327393, 6381375, 6408109, 6457032, 6490600, 6563324, 6658145, 6690842, 6771808, 6804416, 6836567, 6850646, 6856698, 6859907, 6920241, 6941026, 6959112, 6963338, 6975764, 6985625, 6993192, 7006712, 7016539, 7043081, 7058225, 7065262, 7069499, 7088862, 7107519, 7164796, 7175090, 7181066, 7251366, 7720315, JP 3927239

---

Cognex, In-Sight, EasyBuilder, VisionView, DataMan and DVT are registered trademarks of Cognex Corporation.



The Cognex logo, SmartLink, EdgeCount, FeatureCount, and ObjectLocate are trademarks of Cognex Corporation.

Windows is a registered trademark or trademark of Microsoft Corporation in the United States and other countries. Other product and company trademarks identified herein are the trademarks of their respective owners.



# Regulations/Conformity

**Note:** For the most up-to-date regulations and conformity information, please refer to the In-Sight online support site: <http://www.cognex.com/Support/InSight>.

<b>Declaration of Conformity</b>	
Manufacturer	Cognex Corporation One Vision Drive Natick, MA 01760 USA
Declares this	 -marked Machine Vision System Product
Product	In-Sight 7010/7010C/7020/7050: Regulatory Model 1AAA In-Sight 7200/7200C/7210/7230: Regulatory Model 1AAA In-Sight 7400/7400C/7410/7430: Regulatory Model 1AAA In-Sight 7402/7402C/7412/7432: Regulatory Model 1AAA
Complies With	2004/108/EC Electromagnetic Compatibility Directive
Compliance Standards	EN 55022:2006 +A1:2007 Class A EN 61000-6-2:2005 EN 61000-3-2:2006+A1:2009+A2:2009 EN 61000-3-3:2008
European Representative	COGNEX INTERNATIONAL Immeuble "Le Patio" 104 Avenue Albert 1er 92563 Rueil Malmaison Cedex - France
<b>Safety and Regulatory</b>	
FCC	FCC Part 15, Class A This device complies with Part 15 of the FCC Rules. Operation is subject to the following two conditions: (1) this device may not cause harmful interference; and (2) this device must accept any interference received, including interference that may cause undesired operation. This equipment generates, uses, and can radiate radio frequency energy and, if not installed and used in accordance with the instruction manual, may cause harmful interference to radio communications. Operation of this equipment in a residential area is likely to cause harmful interference in which case the user will be required to correct the interference at their own expense.
KCC 	In-Sight 7010/7010C/7020/7050: Regulatory Model 1AAA KCC-REM-CGX-1AAA In-Sight 7200/7200C/7210/7230: Regulatory Model 1AAA KCC-REM-CGX-1AAA In-Sight 7400/7400C/7410/7430: Regulatory Model 1AAA KCC-REM-CGX-1AAA In-Sight 7402/7402C/7412/7432: Regulatory Model 1AAA KCC-REM-CGX-1AAA
NRTL	TÜV SÜD AM SCC/NRTL OSHA Scheme for UL/CAN 60950-1. Regulatory Model 1AAA.
CB	TÜV SÜD AM, IEC/EN 60950-1. CB report available upon request.
RoHS	RoHS 6 Compliant.



# Precautions

Observe these precautions when installing the vision system to reduce the risk of injury or equipment damage:

- The In-Sight vision system is intended to be supplied by a UL or NRTL listed power supply with a 24VDC output rated for at least 2A continuous and a maximum short circuit current rating of less than 8A and a maximum power rating of less than 100VA and marked Class 2 or Limited Power Source (LPS). Any other voltage creates a risk of fire or shock and can damage the components. Applicable national and local wiring standards and rules must be followed.
- According to IEC 62471, the white ring light is in Risk Group 1; it is not recommended to stare directly into the illumination LEDs when the vision system is receiving power. According to IEC 62471, the blue ring light is in Risk Group 2; CAUTION – Possibly hazardous optical radiation emitted from this product. Do not stare at operating light. May be harmful to the eyes. The green ring light, the red ring light and the Infrared (IR) ring light are Exempt Group products, therefore no precautions are required.
- Do not install In-Sight vision systems where they are directly exposed to environmental hazards such as excessive heat, dust, moisture, humidity, impact, vibration, corrosive substances, flammable substances, or static electricity.
- To reduce the risk of damage or malfunction due to over-voltage, line noise, electrostatic discharge (ESD), power surges, or other irregularities in the power supply, route all cables and wires away from high-voltage power sources.
- Do not expose the image sensor to laser light; image sensors can be damaged by direct, or reflected, laser light. If your application requires the use of laser light that may strike the image sensor, a lens filter at the corresponding laser's wavelength is recommended. Contact your local integrator or application engineer for suggestions.
- The In-Sight vision system does not contain user-serviceable parts. Do not make electrical or mechanical modifications to In-Sight vision system components. Unauthorized modifications may void your warranty.
- Changes or modifications not expressly approved by the party responsible for regulatory compliance could void the user's authority to operate the equipment.
- Service loops should be included with all cable connections.
- Cable shielding can be degraded or cables can be damaged or wear out more quickly if a bend radius or service loop is tighter than 10X the cable diameter.
- Class A Equipment (broadcasting and communication equipment for office work): Seller and user shall be notified that this equipment is suitable for electromagnetic equipment for office work (Class A) and can be used outside the home.
- This device should be used in accordance with the instructions in this manual.





# Table of Contents

<b>Legal Notices</b> .....	<b>i</b>
<b>Regulations/Conformity</b> .....	<b>iii</b>
<b>Precautions</b> .....	<b>v</b>
<b>Introduction</b> .....	<b>1</b>
Support .....	1
Standard Components .....	1
Cables .....	2
Ethernet Cable .....	2
Light Cable .....	2
Power and I/O Breakout Cable .....	2
<b>Installation</b> .....	<b>3</b>
Connectors and Indicators .....	3
Install the Lens (C-Mount Lens Configuration) .....	5
Mount the Vision System .....	6
Working Distance and Field of View .....	7
Connect the Light Cable (Optional) .....	9
Connect the Ethernet Cable .....	9
Connect the Power and I/O Breakout Cable .....	10
<b>Specifications</b> .....	<b>11</b>
Vision System Specifications .....	11
I/O Specifications .....	13
Acquisition Trigger Input .....	13
General-Purpose Inputs .....	14
High-Speed Outputs .....	16
RS-232 Receive and Transmit .....	18
RS-232 Connector Configuration .....	18
Light Connector .....	19
Ethernet Cable Specifications .....	20
Light Cable Specifications .....	21
Power and I/O Breakout Cable Specifications .....	22
Vision System Dimensions .....	23
<b>Appendix A - Cleaning/Maintenance</b> .....	<b>27</b>
Clean the Vision System Housing .....	27
Clean the Vision System Image Sensor Window (C-Mount Lens Configuration) .....	27
<b>Appendix B - Connect the I/O Module</b> .....	<b>29</b>



# Introduction

The In-Sight® vision system is a compact, network-ready, stand-alone machine vision system used for automated inspection, measurement, identification and robot guidance applications on the factory floor. All models can be easily configured remotely over a network using an intuitive user interface.

## Support

Many information resources are available to assist you in using the vision system:

- *In-Sight® Explorer Help*, an online HTML Help file provided with In-Sight Explorer software.
- In-Sight computer-based tutorials provided on CD-ROM with selected In-Sight starter accessories kits.
- The In-Sight online support site: <http://www.cognex.com/Support/InSight>.

## Standard Components

The vision system is shipped with the components listed below.

**Table 1-1: Standard Components**

Component	M12 Lens Configuration	C-Mount Lens Configuration
Vision System	X	X
Lens	X	
Lens Cover Kit (includes lens cover and O-Ring)	X	X
LED Ring Light	X	
Mounting Kit	X	

**Table 1-2: Standard Components Descriptions**

Component	Description
Vision System	Provides vision processing, job storage, serial and Ethernet connectivity and discrete I/O.
Lens	Provides image formation. The vision system is shipped with the lens pre-installed with the M12 lens configuration.  <b>Note:</b> If you purchased a vision system with the pre-installed M12 lens, the lens can be replaced with other M12 lenses. The Cognex Lens Tool accessory (LNS-M12-TOOLKIT) must be used to replace the M12 lens. Please contact your Cognex sales representative for more information.
Lens Cover Kit (includes lens cover and O-Ring)	Provides environmental protection for the lens.
LED Ring Light	Provides internal lighting. The vision system is shipped with an internal LED ring light pre-installed with the M12 lens configuration.
Mounting Kit	Includes a mounting bracket and M3 screws (quantity 4) for mounting the vision system and securing it to a mounting surface.

## Cables

**Note:** Cables are sold separately.

**CAUTION:** All cable connectors are “keyed” to fit the connectors on the vision system; do not force the connections or damage may occur.

## Ethernet Cable

The Ethernet cable is used to connect the vision system to other network devices. The pin-outs for the cable are listed in the [Ethernet Cable Specifications on page 20](#). This cable is available in the lengths and styles listed below.

**Table 1-3: Ethernet Cables**

Length	Standard Part #	45-Degree Key Right-Angle Part #	135-Degree Key Right Angle Part #
0.6 m	CCB-84901-1001-00	N/A	N/A
2 m	CCB-84901-1002-02	CCB-84901-6005-02	CCB-84901-7005-02
5 m	CCB-84901-1003-05	CCB-84901-6001-05	CCB-84901-7001-05
10 m	CCB-84901-1004-10	CCB-84901-6002-10	CCB-84901-7002-10
15 m	CCB-84901-1005-15	CCB-84901-6003-15	CCB-84901-7003-15
30 m	CCB-84901-1006-30	CCB-84901-6004-30	CCB-84901-7004-30

## Light Cable

The Light cable is used to connect the vision system to an external lighting device, providing power and strobe control. The pin-outs for the cable are listed in the [Light Cable Specifications on page 21](#). This cable is available in the lengths listed below.

**Table 1-4: Light Cables**

Length	Standard Part #
0.5 m	CCB-M12LTF-00
1 m	CCB-M12LTF-01
2 m	CCB-M12LTF-02
5 m	CCB-M12LTF-05

## Power and I/O Breakout Cable

The Power and I/O Breakout cable provides connections to an external power supply, the acquisition trigger input, general-purpose inputs, high-speed outputs, and RS-232 serial communications. The pin-outs for the cable are listed in the [Power and I/O Breakout Cable Specifications on page 22](#). This cable is available in the styles listed below.

**Table 1-5: Power and I/O Breakout Cables**

Length	Standard Part #	Right-Angle Part #
5 m	CCB-PWRIO-05	CCB-PWRIO-05R

# Installation

This section describes the connection of the vision system to its standard and optional components. For a complete list of options and accessories, contact your Cognex sales representative.

**Note:**

- Cables are sold separately.
- If any of the standard components appear to be missing or damaged, immediately contact your Cognex Authorized Service Provider (ASP) or Cognex Technical Support.

**CAUTION:** All cable connectors are “keyed” to fit the connectors on the vision system; do not force the connections or damage may occur.

## Connectors and Indicators

Table 2-1: Vision System Connectors

Connector	Function
ENET Connector	Connects the vision system to a network. The ENET connector provides the Ethernet connection to external network devices. For more information, refer to the <a href="#">Ethernet Cable Specifications on page 20</a> .
LIGHT Connector	Connects the vision system to an external lighting device. For more information, refer to the <a href="#">Light Cable Specifications on page 21</a> .
PWR Connector	Connects the Power and I/O Breakout cable, which provides connections to an external power supply, the acquisition trigger input, general-purpose inputs, high-speed outputs, and RS-232 serial communications. For more information, refer to the <a href="#">Power and I/O Breakout Cable Specifications on page 22</a> .

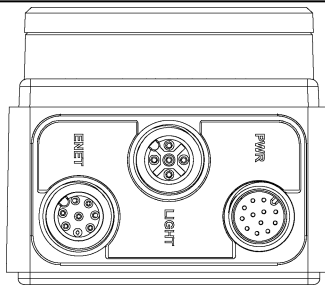

**Table 2-2: Vision System Indicators**

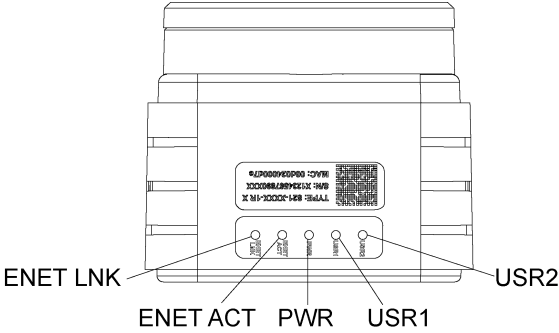

Indicator	Function
ENET LNK LED	Solid green when a network connection is detected.
ENET ACT LED	Flashes green when there is network activity.
PWR LED	Solid green when power is applied.
USR1 LED	Red when active. User-configurable using Discrete Output Line 5 (Line 13 when using the CIO-MICRO or CIO-MICRO-CC I/O module).
USR2 LED	Green when active. User-configurable using Discrete Output Line 4 (Line 12 when using the CIO-MICRO or CIO-MICRO-CC I/O module).

When utilizing a POWERLINK-enabled In-Sight vision system, the vision system's LEDs are used to convey POWERLINK-specific behavior status updates. The USR1 LED is used as the POWERLINK error LED, and the USR2 LED is used as POWERLINK status LED.

**Table 2-3: POWERLINK Indicators**

Indicator	LED Behavior	Function
USR1 LED	Solid red	POWERLINK is in an error state.
USR2 LED	Off	POWERLINK is initializing.
	Blinking at 10Hz	POWERLINK is in basic Ethernet mode (i.e., a POWERLINK Master Node has not been detected on the network).
	One short flash (200ms), followed by a long OFF phase (1000ms)	The vision system has detected a Master Node on the POWERLINK network, however, isochronous communications have not been detected.
	Two short flashes, followed by a long OFF phase	The POWERLINK network has begun isochronous communications, but the vision system has not been configured to participate.
	Three short flashes, followed by a long OFF phase	The Node device has completed configuration, and is awaiting a signal from the Master Node to begin isochronous communications.
	On	The Node device is communicating on the POWERLINK network.
	Blinking at 2.5Hz	The POWERLINK Node has stopped due to an error.

## Install the Lens (C-Mount Lens Configuration)

There are two lens configurations available for the vision system: an M12 lens configuration; and a C-Mount lens configuration. If you purchased a vision system with the M12 lens configuration, the vision system is shipped with the lens pre-installed and no additional installation is required. If you purchased a vision system with the C-Mount lens configuration, you will need to complete the following steps to install the lens to the vision system.

**Note:**

- Autofocus is not supported for the C-Mount lens configuration.
- If you purchased a vision system with the pre-installed M12 lens, the lens can be replaced with other M12 lenses. The Cognex Lens Tool accessory (LNS-M12-TOOLKIT) must be used to replace the M12 lens. Please contact your Cognex sales representative for more information.

**CAUTION:** Using a non-Cognex lens or replacing the M12 lens without the Cognex Lens Tool accessory (LNS-M12-TOOLKIT) may cause damage to the vision system.

1. Remove the protective cap and the protective film covering the image sensor, if present.
2. Attach a C-Mount lens to the vision system. The exact lens focal length needed depends on the working distance and the field of view required for your machine vision application.
3. If using a lens cover, attach the lens cover to the vision system.

**Tip:** The lens cover is designed with a maximum 8mm travel extension to accommodate different length lenses and still maintain an IP67 rating. When installing the lens cover, push the lens cover down as close to the lens as possible.

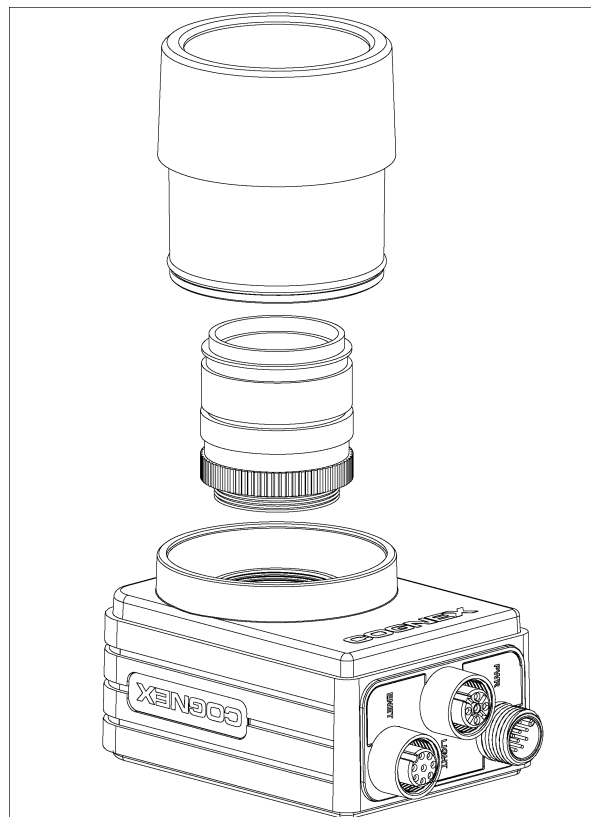

Figure 2-1: Install the C-Mount Lens

## Mount the Vision System

The mounting kit includes a mounting bracket and M3 screws (quantity 4) for mounting the vision system and securing it to a mounting surface. The mounting bracket also has 1/4 - 20, M6 and flathead mounting holes available for mounting the vision system to a mounting surface.

**Note:** The mounting kit is only shipped with vision systems with the M12 lens configuration. If you purchased a vision system with the C-Mount lens configuration, the mounting kit is not included in the box, but can be purchased as an optional component. Please contact your Cognex sales representative for more information.

**CAUTION:**

- When mounting the vision system with the mounting bracket, use the M3 screws supplied with the mounting kit.
- If using the 1/4 - 20 or M6 screw holes on the mounting bracket to secure the vision system to a mounting surface, the insertion depth of the screw should not exceed 7mm. Allowing the mounting screw to bottom in the mounting hole can damage the vision system.
- If mounting the vision system without the mounting bracket, the exposed thread length of the M3 screw should not exceed 3mm. The total length of the M3 screw should be 3mm, plus the thickness of the mounting material used. Otherwise, it may damage the vision system.

1. Align the mounting block with the mounting holes on the vision system.
2. Insert the M3 screws (quantity 4) into the mounting holes and tighten the screws using a 2.5mm hex wrench; the maximum torque is 0.9039 Nm (8 in-lb).

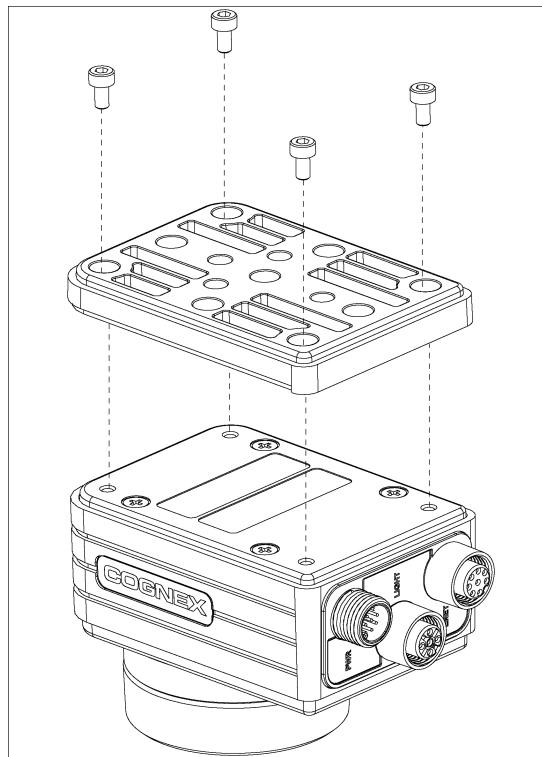

**Figure 2-2: Mount the Vision System**



## Working Distance and Field of View

The distance from the vision systems' lens to the part that needs to be inspected is the working distance; field of view is what the vision system can see at that distance. As the working distance increases, so does the size of the field of view.

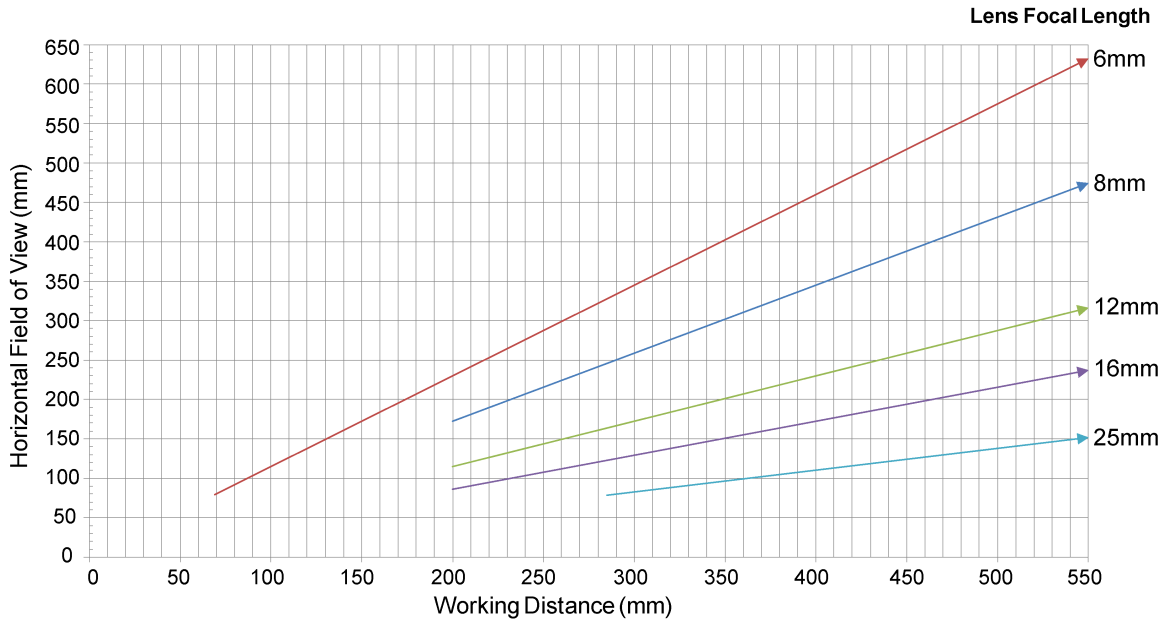

Figure 2-3: Vision System with 1280 x 1024 Resolution (mm)

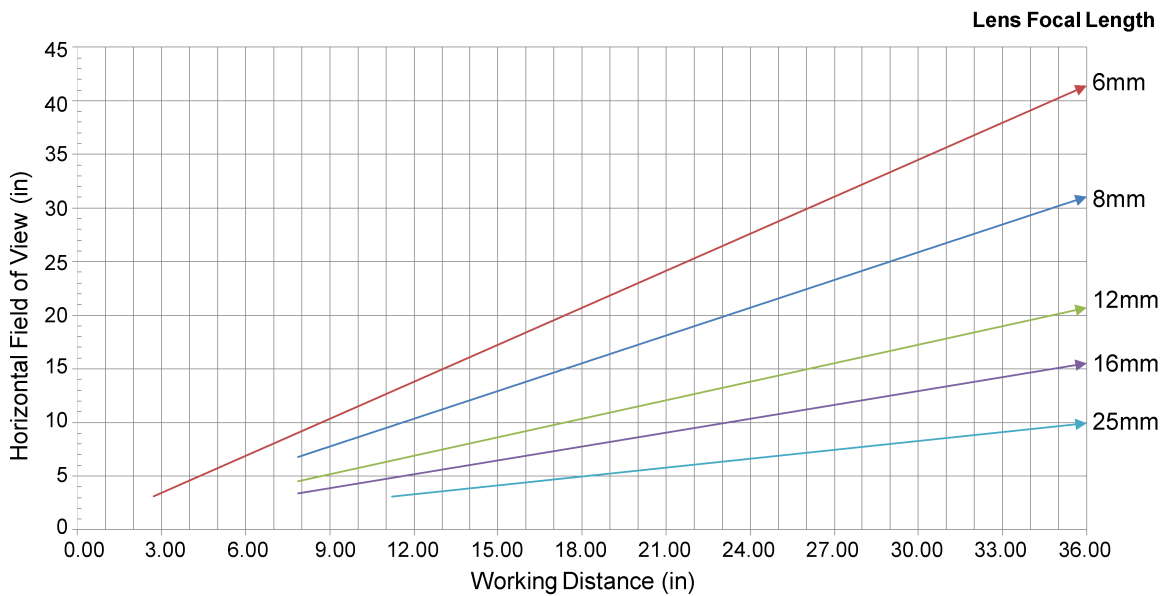
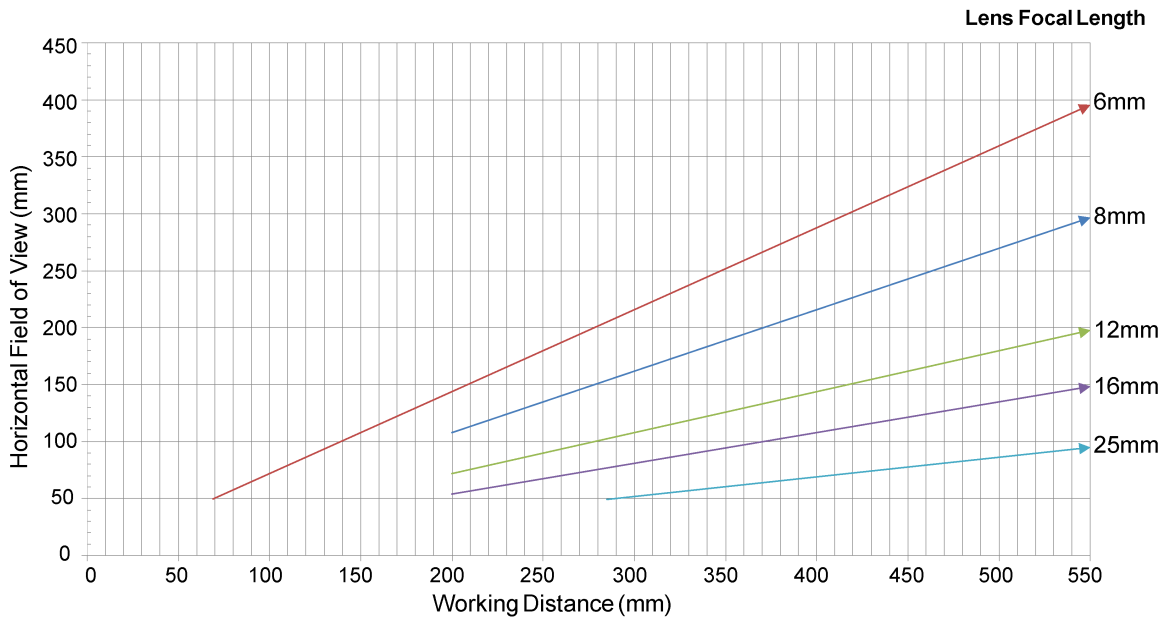
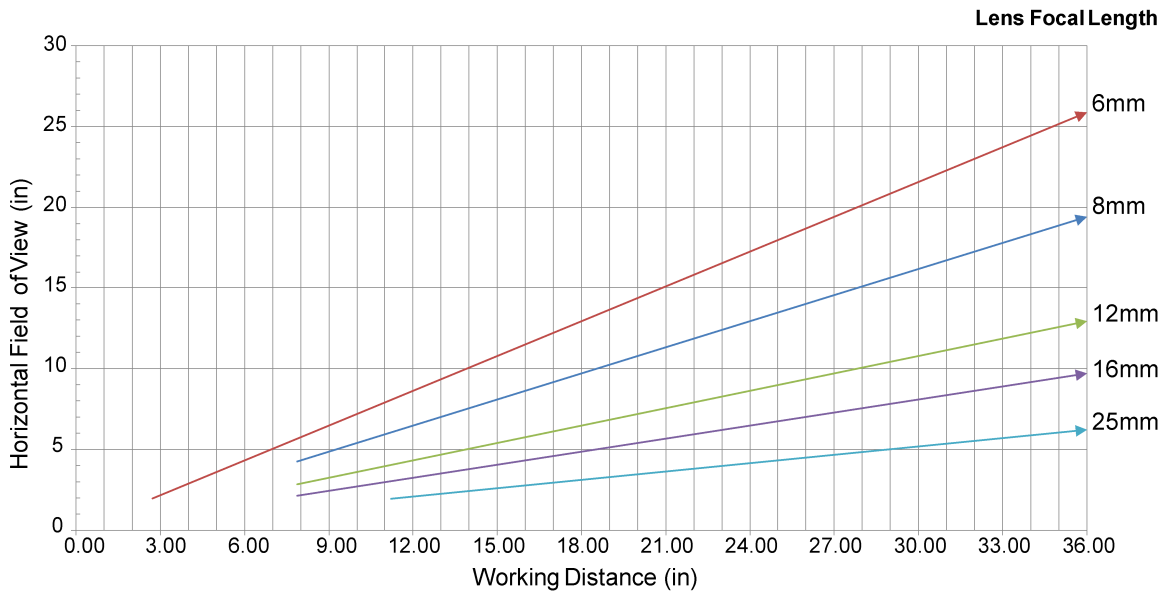

Figure 2-4: Vision System with 1280 x 1024 Resolution (in)



**Figure 2-5: Vision System with 800 x 600 Resolution (mm)**

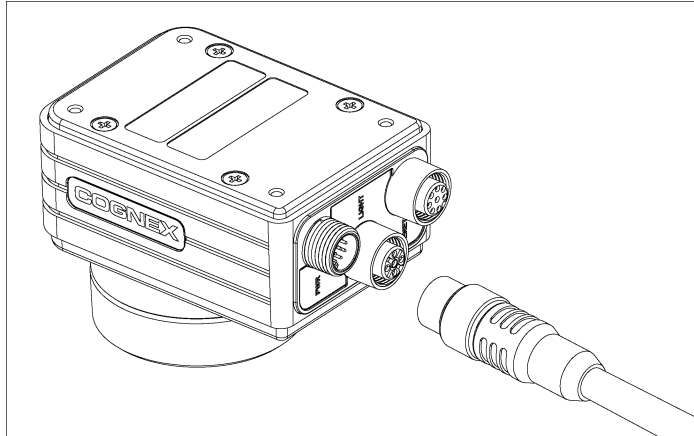

**Figure 2-6: Vision System with 800 x 600 Resolution (in)**

## Connect the Light Cable (Optional)

**Tip:** The space between the vision system connectors is limited; it is recommended to first connect the Light cable to ensure enough space for the connection of the Ethernet cable and Power and I/O Breakout cable.

1. Connect the Light cable's M12 connector to the vision system's M12 LIGHT connector.

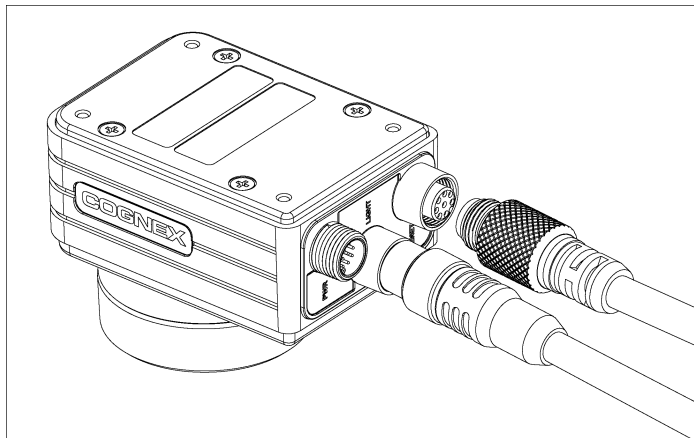

**Figure 2-7: Connect the Light Cable**

2. Connect the other end of the Light cable to an external lighting device (for example, a strobe light). For more information, refer to the [Light Cable Specifications on page 21](#).

## Connect the Ethernet Cable

1. Attach the Ethernet cable's M12 connector to the vision system's M12 ENET connector.



**Figure 2-8: Connect the Ethernet Cable**

2. Connect the Ethernet cable's RJ-45 connector to a switch/router or PC, as applicable.

## Connect the Power and I/O Breakout Cable

**Note:** Unused bare wires can be clipped short or tied back using a tie made of non-conductive material. Keep all bare wires separated from the +24VDC wire.

1. Verify that the 24VDC power supply being used is unplugged and not receiving power.
2. Optionally, connect the I/O or serial wires to an appropriate device (for example, a PLC or a serial device). Refer to [Power and I/O Breakout Cable Specifications on page 22](#) for wiring details.
3. Attach the Power and I/O Breakout cable's +24VDC (Red wire) and GROUND (Black wire) to the corresponding terminals on the power supply. Refer to [Power and I/O Breakout Cable Specifications on page 22](#) for wiring details.

**CAUTION:** Never connect voltages other than 24VDC. Always observe the polarity shown.

4. Connect the Power and I/O Breakout cable's M12 connector to the vision system's PWR connector.

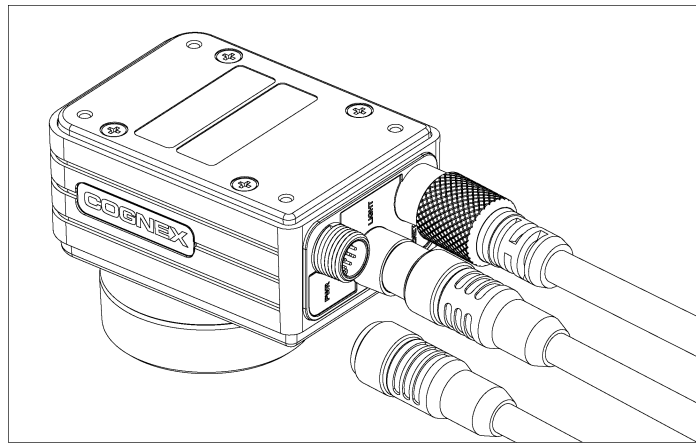

**Figure 2-9: Connect the Power and I/O Breakout Cable**

5. Restore power to the 24VDC power supply and turn it on if necessary.

# Specifications

The following sections list general specifications for the In-Sight vision system.

## Vision System Specifications

**Table 3-1: Vision System Specifications**

Specifications	In-Sight 7010/7020/7050/7200/ 7210/7230/7400/7410/7430	In-Sight 7010C/7200C/7400C	In-Sight 7402/7412/7432	In-Sight 7402C
Minimum Firmware Requirement	In-Sight Version 4.7.1/4.7.3 <sup>1</sup>	In-Sight Version 4.8.0	In-Sight Version 4.7.1/4.7.3 <sup>1</sup>	In-Sight Version 4.8.0
Job/Program Memory	512MB non-volatile flash memory; unlimited storage via remote network device.			
Image Processing Memory	256MB SDRAM			
Sensor Type	1/1.8-inch CMOS			
Sensor Properties	5.3mm diagonal, 5.3 x 5.3µm sq. pixels		8.7mm diagonal, 5.3 x 5.3µm sq. pixels	
Resolution (pixels)	800 x 600		1280 x 1024	
Electronic Shutter Speed	16µs to 950ms			
Acquisition	Rapid reset, progressive scan, full-frame integration.			
Bit Depth	256 grey levels (8 bits/pixel).	24-bit color.	256 grey levels (8 bits/pixel).	24-bit color.
Image Gain/Offset	Controlled by software.			
Frames Per Second <sup>2</sup>	102 full frames per second.	50 full frames per second.	60 full frames per second.	30 full frames per second.
Lens Type	M12 or C-Mount.			
Image Sensor Alignment Variability <sup>3</sup>	±0.127mm (0.005in), (both x and y) from lens C-Mount axis to center of imager.			
Trigger	1 opto-isolated, acquisition trigger input.Remote software commands via Ethernet and RS-232C.			
Discrete Inputs	3 general-purpose inputs when connected to the Power and I/O Breakout cable. (Eight additional inputs available when using the optional CIO-MICRO or CIO-MICRO-CC I/O module.)			
Discrete Outputs	4 high-speed outputs when connected to the Power and I/O Breakout cable. (Eight additional outputs available when using the optional CIO-MICRO or CIO-MICRO-CC I/O module.)			
Status LEDs	Network link and activity, power and 2 user-configurable.			
Internal LED Ring Light	Red, Green, Blue, White, IR (M12 lens configuration only).			
Network Communication	Ethernet port, 10/100 BaseT with auto MDI/MDIX. IEEE 802.3 TCP/IP protocol. Supports DHCP (factory default), static and link-local IP address configuration.			
Serial Communication	RS-232C: 4800 to 115,200 baud rates.			

<sup>1</sup> Firmware version 4.7.1 is the minimum firmware requirement for models with the C-Mount Lens configuration. Firmware version 4.7.3 is the minimum firmware requirement for models with the M12 Lens configuration.

<sup>2</sup> Maximum frames per second is job-dependent, based on the minimum exposure for a full image frame capture using the dedicated acquisition trigger, and assumes there is no user interface connection to the vision system.

<sup>3</sup> Expected variability in the physical position of the image sensor, from vision system-to-vision system. This equates to ~ ±24 pixels on a 800 x 600 resolution CMOS and a 1280 x 1024 resolution CMOS.

Specifications	In-Sight 7010/7020/7050/7200/ 7210/7230/7400/7410/7430	In-Sight 7010C/7200C/7400C	In-Sight 7402/7412/7432	In-Sight 7402C
Power Consumption	24VDC ±10%, 2.0 amp. External Light - Continuously on; output 24V, 500mA Max. External Light - Strobe; output 24V, 1amp Max at 50% duty cycle (max on time of 100ms).			
Material	Aluminum housing.			
Finish	Painted.			
Mounting	Four M3 threaded mounting holes (1/4 - 20, M6 and flathead mounting holes also available on mounting bracket).			
M12 Lens Configuration Dimensions	55mm (2.17in) x 84.8mm (3.34in) x 55mm (2.17in)			
C-Mount Lens Configuration Dimensions	75mm (2.95in) to 83mm (3.27in) x 84.8mm (3.34in) x 55mm (2.17in) with lens cover installed.			
	42.7mm (1.68in) x 84.8mm (3.34in) x 55mm (2.17in) without lens cover installed.			
Weight	220 g (7.8 oz.) with lens cover and typical M12 lens installed.			
Operating Temperature	0°C to 45°C (32°F to 113°F)			
Storage Temperature	-30°C to 80°C (-22°F to 176°F)			
Humidity	90%, non-condensing (Operating and Storage)			
Protection	IP67 with lens cover properly installed.			
Shock	80 G Shock per IEC 60068-2-27.			
Vibration	10 G from 10-500 Hz with 150 grams lens per IEC 60068-2-6.			
Regulatory Compliance	CE, FCC, KCC, TÜV SÜD NRTL, RoHS			

## I/O Specifications

Cable and connector specifications and connection examples for acquisition trigger input, general-purpose inputs, high-speed outputs, RS-232 receive and transmit, and light connectors are provided in the following sections.

### Acquisition Trigger Input

The vision system features one acquisition trigger input, which is optically isolated. The acquisition trigger input can be configured to trigger from either an NPN (current sinking) or PNP (current sourcing) device.

**Table 3-2: Acquisition Trigger Input Specifications**

Specification	Description
Voltage	ON: 20 to 24V (24V nominal)
	OFF: 0 to 3V (0V nominal)
Current	ON: 3.0mA
	OFF: < 2.5mA
	Resistance: ~10,000 Ohms
Delay <sup>1</sup>	90µs maximum latency between leading edge of trigger and start of acquisition. Input pulse should be a minimum of 1ms wide.

To trigger from an NPN type photoelectric sensor or PLC output, connect INPUT COMMON to +24V and TRIGGER to the output of the photoelectric sensor. When the output turns ON, it pulls INPUT COMMON down to 0V, turning the opto-coupler ON.

To trigger from a PNP type photoelectric sensor or PLC output, connect INPUT COMMON to 0V and TRIGGER to the output of the photoelectric sensor. When the output turns ON, it pulls TRIGGER up to +24V, turning the opto-coupler ON.

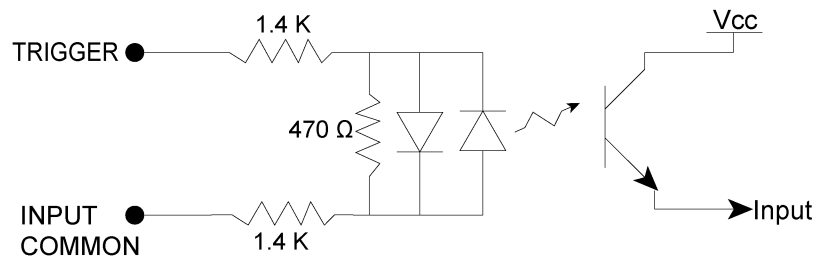

**Figure 3-1: Acquisition Trigger Input Schematic**

<sup>1</sup> Maximum latency is based on a 1µs trigger debounce.

## General-Purpose Inputs

The vision system features three built-in general-purpose inputs, which are optically isolated. The inputs can be configured as either NPN (current sinking) or PNP (current sourcing) lines.

**Note:** Since all general-purpose inputs share a common ground (INPUT COMMON), all connected input devices must be either current sinking or current sourcing.

**Table 3-3: General-Purpose Inputs Specifications**

Specification	Description
Voltage	ON: 20 to 24V (24V nominal)
	OFF: 0 to 3V (0V nominal)
Current	ON: 3.0mA
	OFF: < 2.5mA
	Resistance: ~10,000 Ohms
Delay <sup>1</sup>	90µs maximum latency between leading edge of trigger and start of acquisition. Input pulse should be a minimum of 1ms wide.

For NPN lines, to utilize an input, connect INPUT COMMON to +24V and attach the photoelectric sensor or PLC output to the corresponding input.

For PNP lines, to utilize an input, connect INPUT COMMON to 0V and attach the photoelectric sensor or PLC output to the corresponding input.

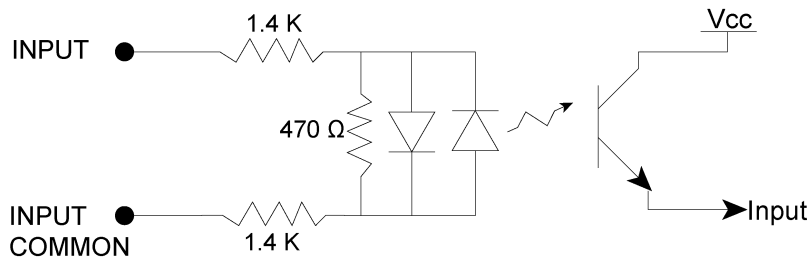

**Figure 3-2: General-Purpose Input Schematic**

<sup>1</sup> Maximum latency is based on a 1µs trigger debounce.



### General-Purpose Input - NPN Configuration

The Power and I/O Breakout cable can be used to connect to an NPN-compatible PLC output. Connect any input directly to the PLC output. For more information, refer to the [Power and I/O Breakout Cable Specifications on page 22](#).

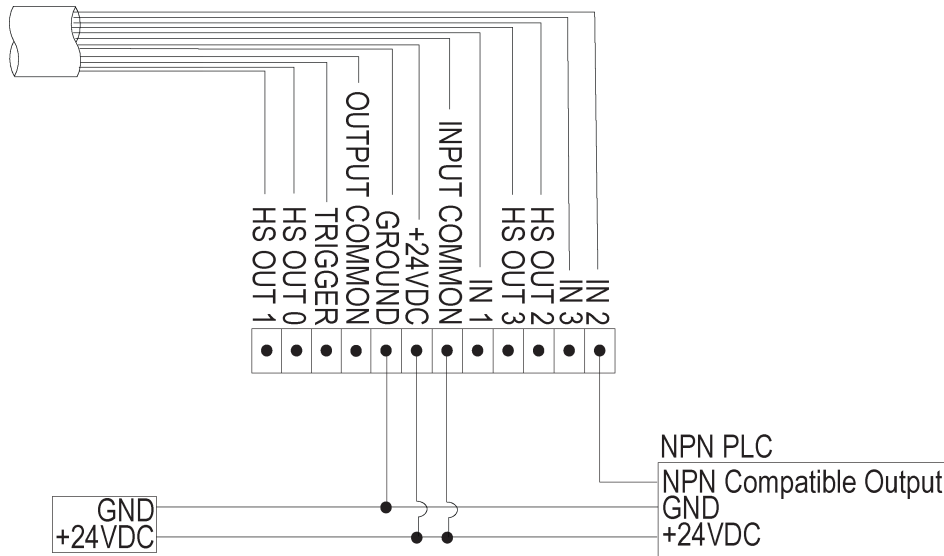

Figure 3-3: General-Purpose Input - NPN Configuration

### General-Purpose Input - PNP Configuration

The Power and I/O Breakout cable can be used to connect to a PNP-compatible PLC output. Connect any input directly to the PLC output. For more information, refer to the [Power and I/O Breakout Cable Specifications on page 22](#).

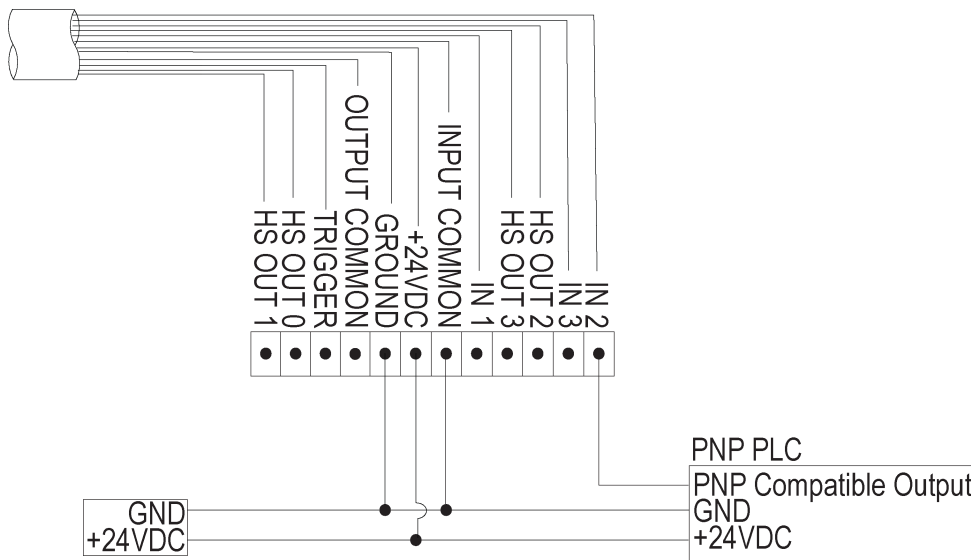

Figure 3-4: General-Purpose Input - PNP Configuration

## High-Speed Outputs

The vision system features four built-in high-speed outputs, which are optically isolated. The outputs can be configured as either NPN (current sinking) or PNP (current sourcing) lines.

**Note:** Since all high-speed outputs share a common ground (OUTPUT COMMON), all connected output devices must be either current sinking or current sourcing.

**Table 3-4: High-Speed Outputs Specifications**

Specification	Description
Voltage	30V maximum through external load.
Current	100mA maximum sink current.
	OFF state leakage current 100µA maximum.
	Internal resistance < 10 Ohms.
	Each line rated at a maximum 100mA, protected against over-current, short circuit and transients from switching inductive loads. High current inductive loads require an external protection diode.
Delay	ON: 750µs maximum latency
	OFF: 200µs maximum latency

For NPN lines, the external load should be connected between the output and the positive supply voltage (+24V nominal). OUTPUT COMMON should be connected to the negative supply voltage (0V). The outputs pull down to 1V or less when ON, which causes current to flow through the load. When the outputs are OFF, no current flows through the load.

For PNP lines, the external load should be connected between the output and the negative supply voltage (0V). When OUTPUT COMMON is connected to the positive supply voltage (+24V nominal), the outputs pull up to 23V or greater when ON, and current flows through the load. When the outputs are OFF, no current flows through the load.

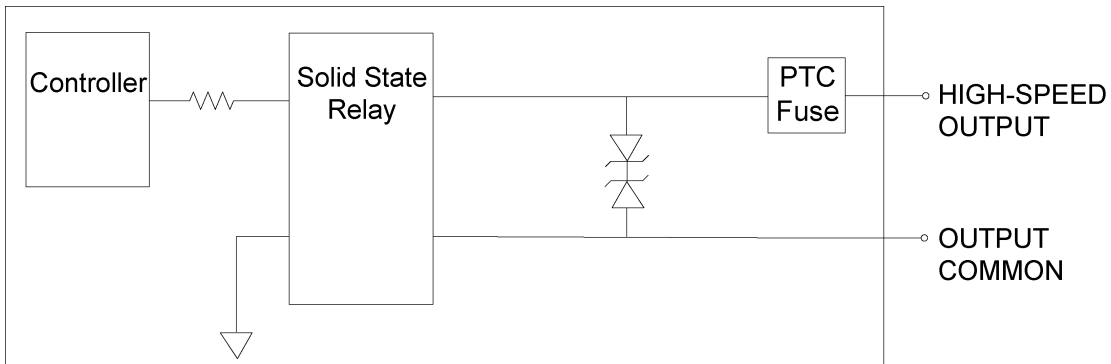

**Figure 3-5: High-Speed Output Schematic**

### High-Speed Output - NPN Configuration

The Power and I/O Breakout cable can be used to connect to an NPN-compatible PLC input. Connect any output directly to the PLC input. When enabled, the output pulls the PLC input down to 1V or less. For more information, refer to the [Power and I/O Breakout Cable Specifications on page 22](#).

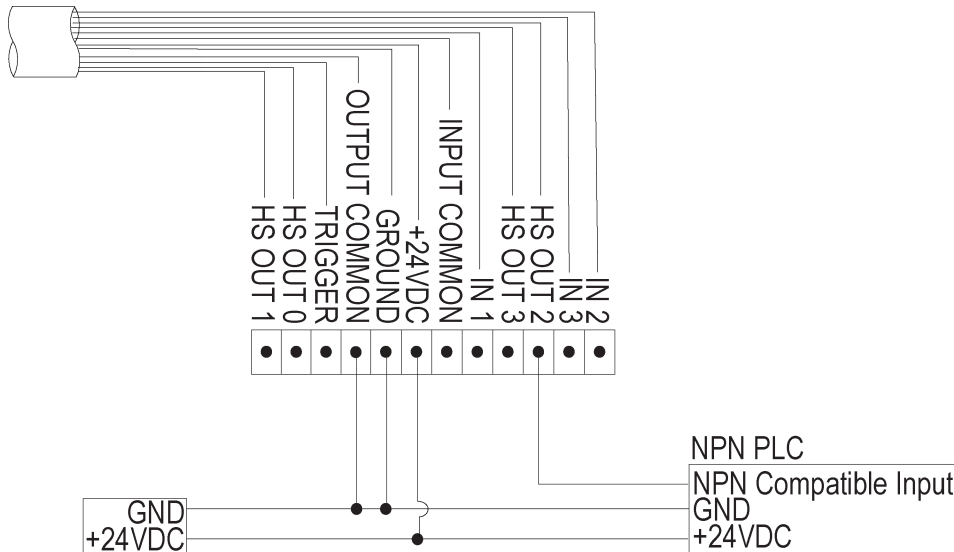

Figure 3-6: High-Speed Output - NPN Configuration

### High-Speed Output - PNP Configuration

The Power and I/O Breakout cable can be used to connect to a PNP-compatible PLC input. Connect any output directly to the PLC input. When enabled, the output pulls the PLC input up to 23V or greater. For more information, refer to the [Power and I/O Breakout Cable Specifications on page 22](#).

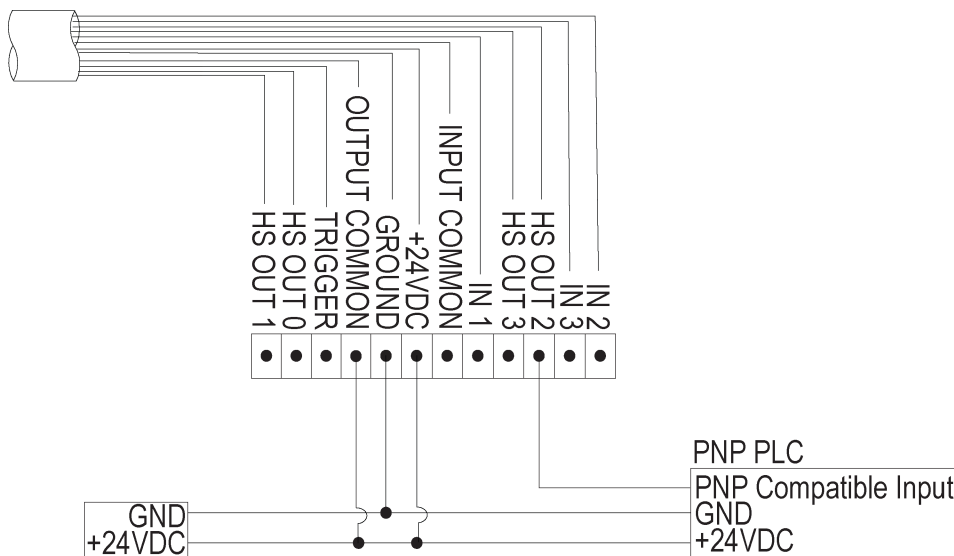

Figure 3-7: High-Speed Output - PNP Configuration

## RS-232 Receive and Transmit

The vision system can be connected to an RS-232 interface, which is non-isolated. When enabled, the RS-232 RECEIVE signal replaces IN 1, and the RS-232 TRANSMIT signal replaces HS OUT 1.

**Table 3-5: RS-232 Receive and Transmit Specifications**

Specification	Description
Resistance	>10,000 Ohms
Baud rates	4800, 9600, 19200, 38400, 57600 and 115200.
Data Bits	7, 8
Stop Bits	1, 2
Parity	None, even and odd.
Handshaking	Software: Xon/Xoff.
	Hardware: None. <sup>1</sup>

## RS-232 Connector Configuration

The Power and I/O Breakout cable can be used to connect to an RS-232 connector. For more information, refer to the [Power and I/O Breakout Cable Specifications on page 22](#).

**Tip:** If the serial signal output is not detected, make sure the ground line is connected between the PC and the vision system.

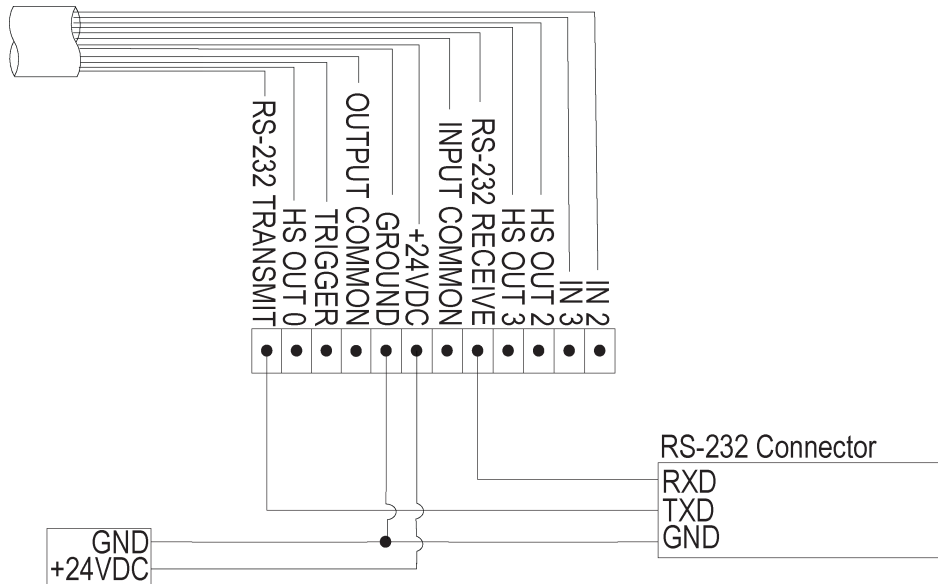

**Figure 3-8: RS-232 Connector Configuration**

<sup>1</sup> If hardware handshaking is required, an I/O module must be used.

## Light Connector

The vision system's light connector can be configured to support either continuous illumination mode or strobed illumination mode.

### Continuous Illumination

The Light connector can be used to provide continuous illumination. In continuous illumination mode, the external current consumption is limited to 500mA. For more information, refer to the [Light Cable Specifications on page 21](#).

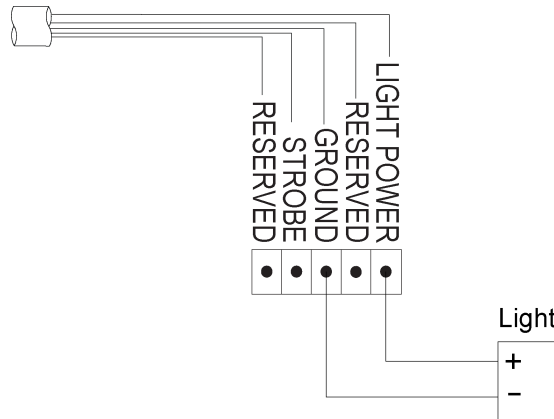

Figure 3-9: Continuous Illumination

### Strobed Illumination

The Light connector can be used to provide strobed illumination. In strobed illumination mode, the current consumption is limited by the duty cycle and the peak on power. The strobe control signal can be configured to actively drive a light control in either a PNP or NPN configuration. For more information, refer to the [Light Cable Specifications on page 21](#).

**Note:** A pull-down or pull-up resistor may be required for either a PNP or NPN configuration, depending on the light vendor.

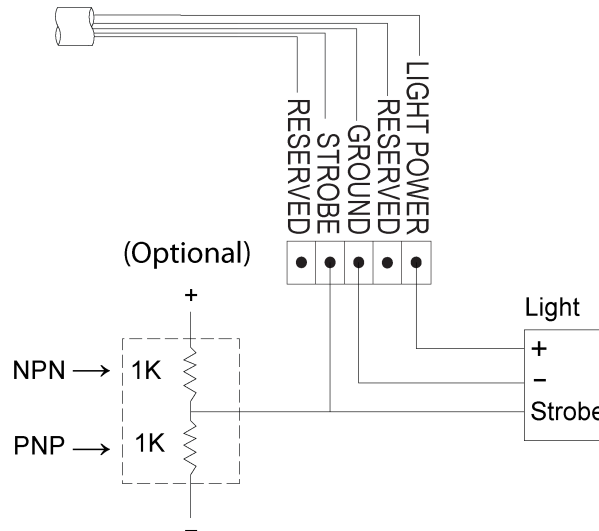
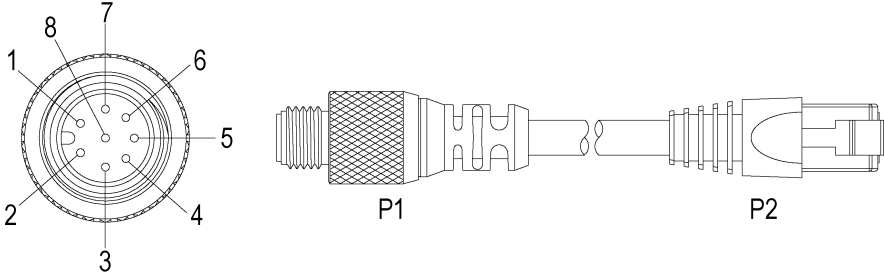

Figure 3-10: Strobed Illumination

## Ethernet Cable Specifications

The Ethernet cable is used to connect the vision system to other network devices. The Ethernet cable can be connected to a single device or provide connections to multiple devices via a network switch or router.

**Table 3-6: Ethernet Cable Pin-Out**



The diagram shows a cross-section of the P1 connector with eight pins numbered 1 through 8. Pin 1 is at the top-left, pin 2 at the bottom-left, pin 3 at the bottom, pin 4 at the bottom-right, pin 5 at the top-right, pin 6 at the top, pin 7 at the top-center, and pin 8 at the top-left-center. To the right, a side view of the cable shows the P1 connector on the left and the P2 connector on the right.

P1 Pin#	Signal Name	Wire Color	P2 Pin#
6	TPO+	White/Orange	1
4	TPO-	Orange	2
5	TPI+	White/Green	3
7	TRMA	Blue	4
1	TRMB	White/Blue	5
8	TPI-	Green	6
2	TRMC	White/Brown	7
3	TRMD	Brown	8

**Note:**

- Cables are sold separately.
- The wiring for this cable follows standard industrial Ethernet M12 specifications. This varies from the 568B standard.

## Light Cable Specifications

The Light cable is used to connect the vision system to an external lighting device, providing power and strobe control.

**Table 3-7: Light Cable Pin-Out**

Pin#	Signal Name	Wire Color
1	LIGHT POWER	Brown
2	RESERVED	White
3	GROUND	Blue
4	STROBE	Black
5	RESERVED	Grey

**Note:** Cables are sold separately.

## Power and I/O Breakout Cable Specifications

The Power and I/O Breakout cable provides connections to an external power supply, the acquisition trigger input, general-purpose inputs, high-speed outputs, and RS-232 serial communications. The Power and I/O Breakout cable is not terminated.

**Table 3-8: Power and I/O Breakout Cable Pin-Out**

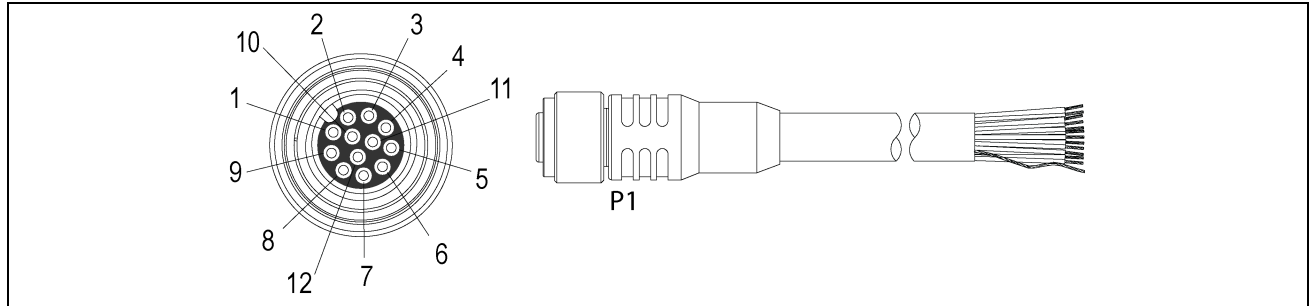

Pin#	Signal Name (I/O Mode)	Wire Color
1	IN 2	Yellow
2	IN 3	White/Yellow
3	HS OUT 2	Brown
4	HS OUT 3	White/Brown
5	IN 1/ RS-232 RECEIVE <sup>1</sup>	Violet
6	INPUT COMMON	White/Violet
7	+24VDC	Red
8	GROUND	Black
9	OUTPUT COMMON	Green
10	TRIGGER	Orange
11	HS OUT 0	Blue
12	HS OUT 1/ RS-232 TRANSMIT <sup>2</sup>	Grey
Shell	SHIELD	Bare Wire

**Note:**

- Cables are sold separately.
- Unused bare wires can be clipped short or tied back using a tie made of non-conductive material. Keep all bare wires separated from the +24VDC wire.

<sup>1</sup> If hardware handshaking is required, an I/O module must be used.

<sup>2</sup> If hardware handshaking is required, an I/O module must be used.



# Vision System Dimensions

**Note:**

- All dimensions are in millimeters [inches] and are for reference purposes only.
- All specifications may be changed without notice.

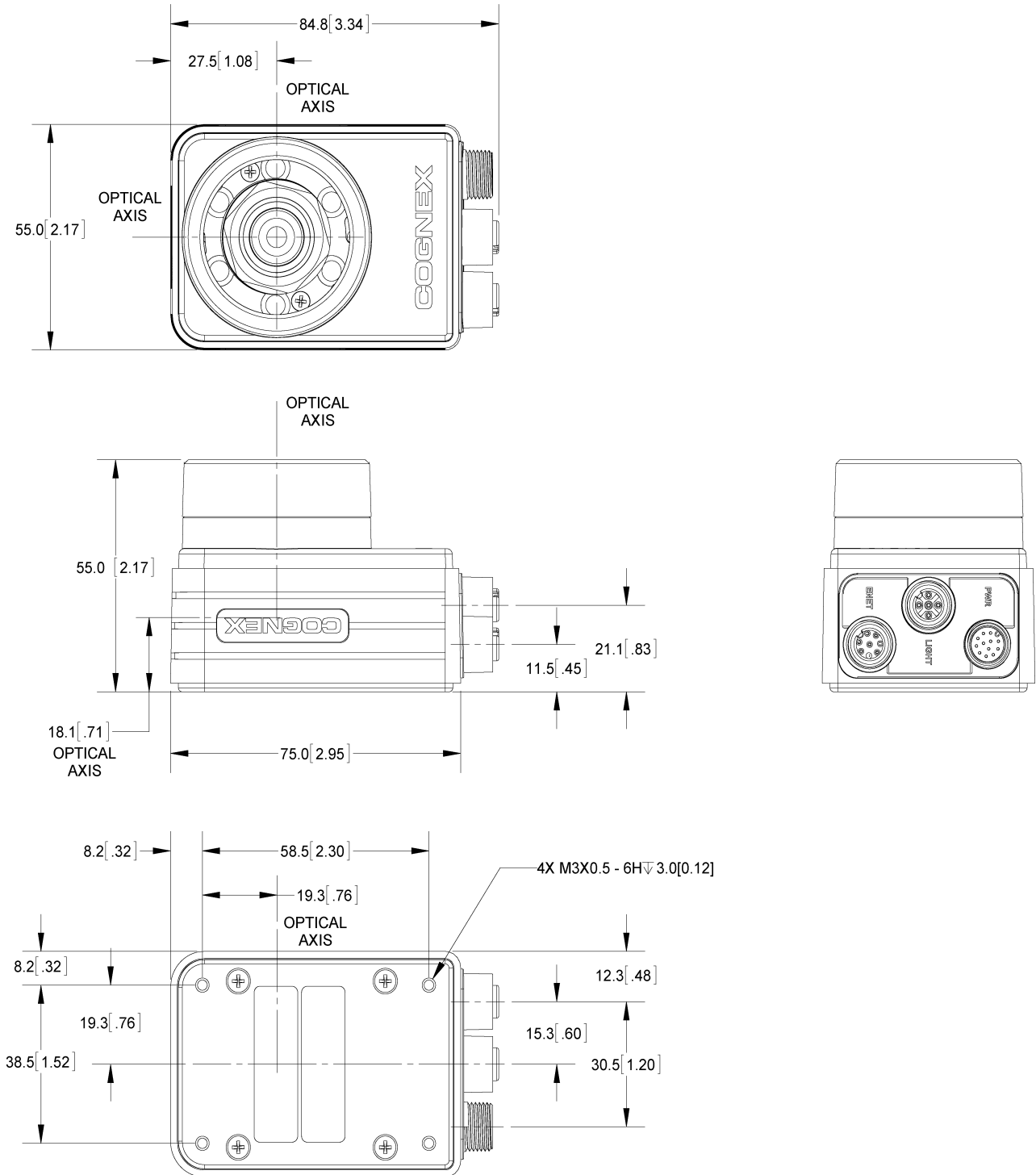

Figure 3-11: M12 Lens Configuration



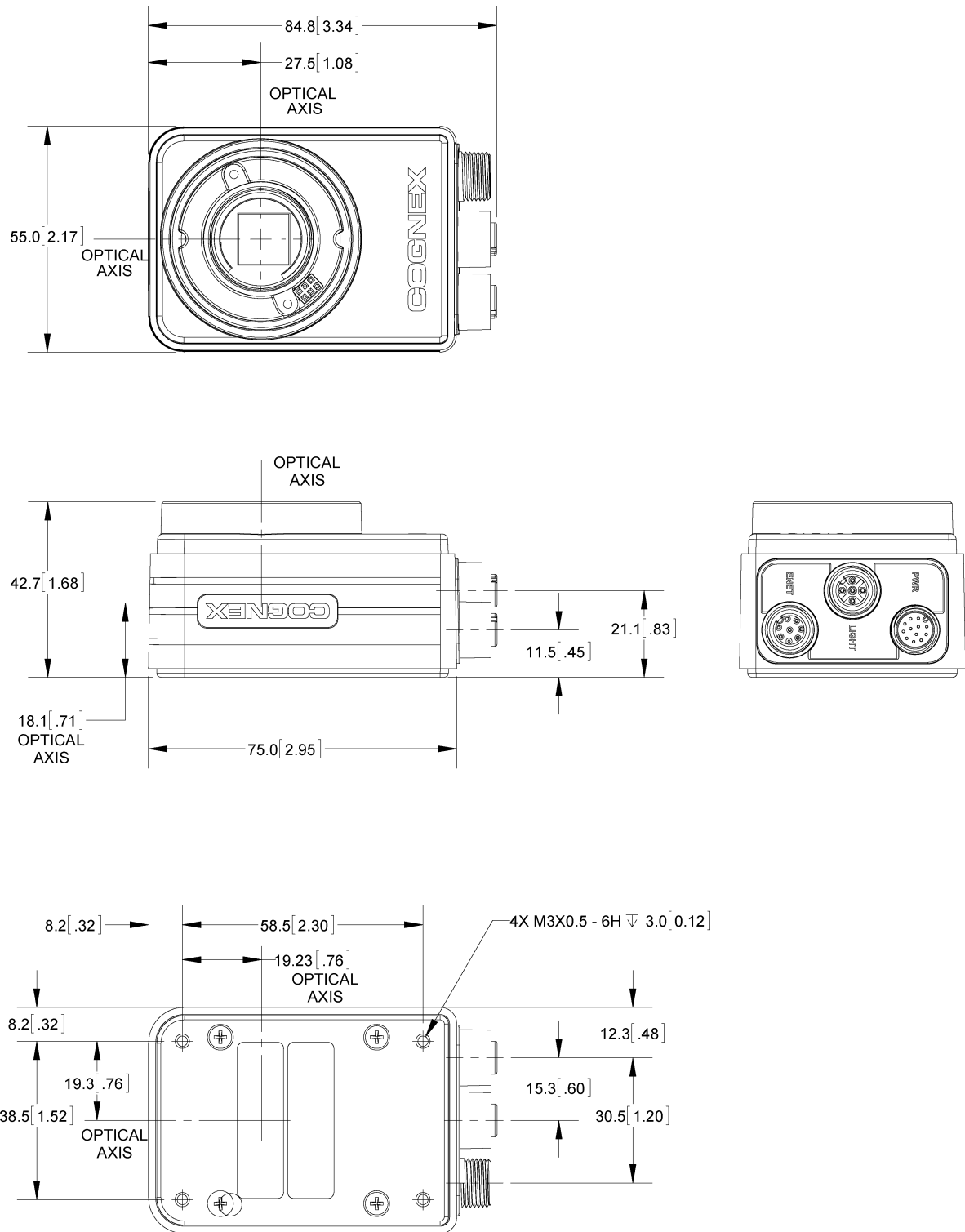

Figure 3-13: C-Mount Lens Configuration (Without Lens Cover)



# Appendix A - Cleaning/Maintenance

## Clean the Vision System Housing

To clean the outside of the vision system housing, use a small amount of mild detergent cleaner or isopropyl alcohol on a cleaning cloth. Do not pour the cleaner directly onto the vision system housing.

---

**CAUTION:** Do not attempt to clean any In-Sight product with harsh or corrosive solvents, including lye, methyl ethyl ketone (MEK) or gasoline.

---

## Clean the Vision System Image Sensor Window (C-Mount Lens Configuration)

To remove dust from the outside of the image sensor window, use a pressurized air duster. The air must be free of oil, moisture or other contaminants that could remain on the glass and possibly degrade the image. Do not touch the glass window. If oil/smudges still remain, clean the window with a cotton bud using alcohol (ethyl, methyl or isopropyl). Do not pour the alcohol directly on the window.



# Appendix B - Connect the I/O Module

In addition to the built-in general-purpose inputs and high-speed outputs available when using the Power and I/O Breakout cable, the optional CIO-MICRO or CIO-MICRO-CC I/O module can be used to provide additional discrete inputs and outputs, hardware handshaking for serial communications and CC-Link communication capability (CIO-MICRO-CC only). When connected to the I/O module, the Power and I/O Breakout cable must be used to supply power to the vision system.

**CAUTION:**

- The I/O module's TRIGGER+, TRIGGER-, HS OUT 0, HS OUT 1 and HS COMMON terminals are not supported with the vision system. Do not connect wire leads from remote devices to these terminals.
- The I/O module's I/O port (DB15) is not supported with the vision system. Do not connect anything to this port.
- If the vision system is configured for use with the I/O module, the RS-232 TRANSMIT and RS-232 RECEIVE pins on the Power and I/O Breakout cable are disabled. Use the I/O module's RS-232 OUT port (DB9) to connect to a serial device.
- All cable connectors are “keyed” to fit the connectors on the vision system; do not force the connections or damage may occur.

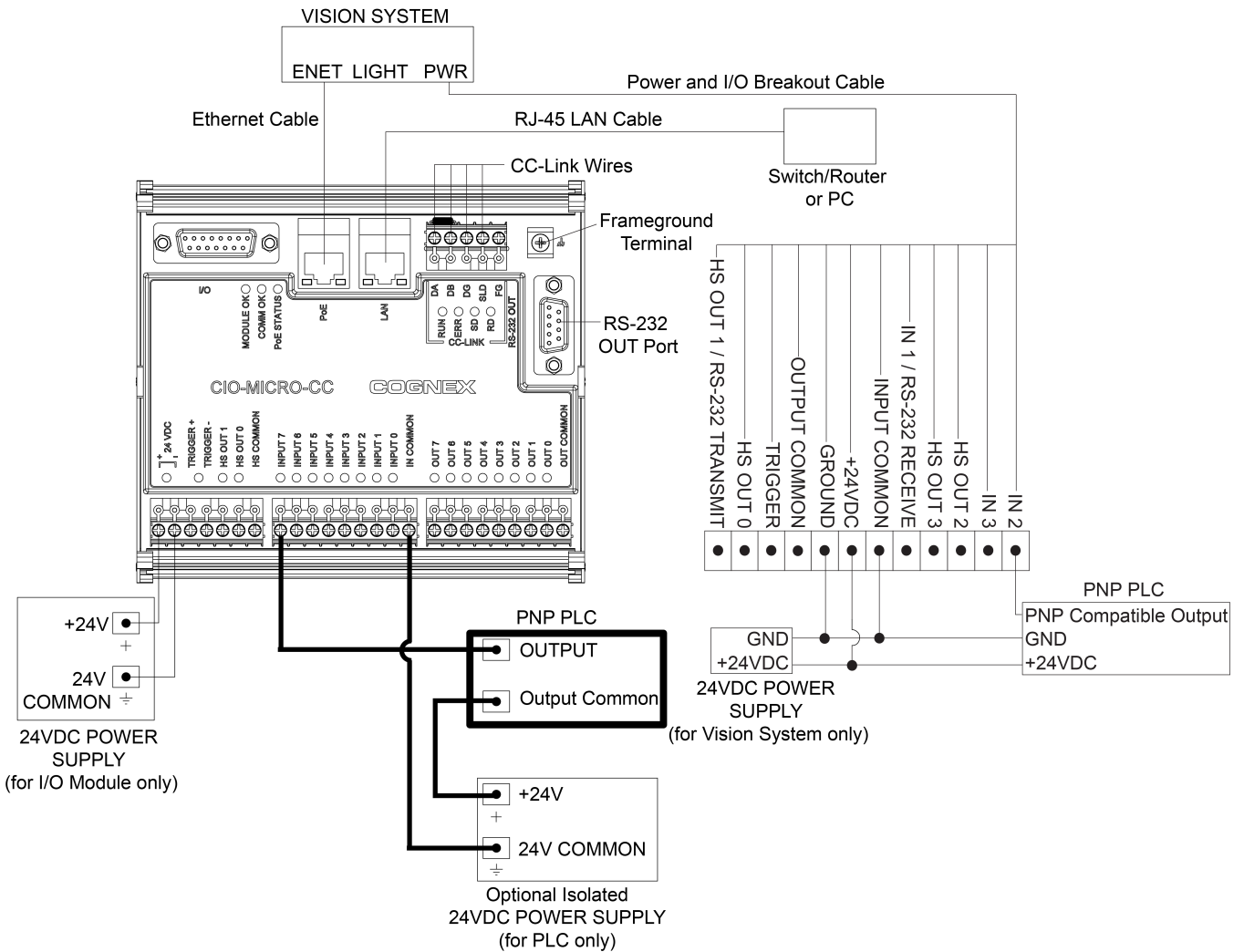

Figure B-1: I/O Module Connections

**Tip:** The power supplies for the vision system and I/O module can be combined into a single power supply, provided the single power supply meets the capacity requirements of the two devices.

1. Connect the I/O Module's power wires.

**Note:** Never connect the I/O module to a power source other than 24VDC. Any other voltage creates a risk of fire or shock and can damage the hardware. Do not connect the 24VDC power source to any terminals other than the 24VDC + and – power connectors.

- a. Verify that the I/O module's 24VDC power supply is unplugged and not receiving power.
  - b. Use a screwdriver to loosen the I/O module's power terminals (labeled 24VDC + and –).
  - c. Insert the 24VDC + and – wires (16 - 22 AWG, solid or stranded wire) from the power supply into the 24VDC + and – terminals on the I/O module.
  - d. Tighten the screw terminals with the screwdriver to secure the wire leads in the terminal block; the maximum torque is 0.1921 Nm (1.7 in-lb).
2. Connect a frame ground wire to the I/O module's Frame Ground terminal. Connect the other end of the frame ground wire to frame ground.

**CAUTION:** The shield ground connections of the RS-232 port, LAN port, PoE port, I/O port and Frame Ground terminal are internally connected. The system grounding is designed to be at a zero ground potential; this zero ground potential extends through the cable and to peripheral equipment (e.g. a vision system, PLC, etc.). To ensure safe operating conditions, it is strongly recommended that all ground connections are checked to ensure that a zero ground potential is met.

3. Connect the I/O module's I/O wires.

**Note:** The I/O module supports both NPN (current sinking) and PNP (current sourcing) devices. For examples of NPN configurations, refer to the *In-Sight<sup>®</sup> CIO-MICRO and CIO-MICRO-CC I/O Modules Installation Manual*.

- a. Determine how I/O devices will be connected to the I/O module's input and output terminals.
  - b. Use a screwdriver to loosen the appropriate screw terminals.
  - c. Insert the input and output wires (16 - 22 AWG, solid or stranded wire) to the input and output terminals. Connect the other end of the input and output wires to the applicable I/O device.
  - d. Tighten the screw terminals with the screwdriver to secure the wire leads in the terminal block; the maximum torque is 0.1921 Nm (1.7 in-lb).
4. Optionally, connect the I/O module to a CC-Link device.

**Note:** The CC-Link terminals are only available on the CIO-MICRO-CC I/O module.

- a. Determine how CC-Link devices will be connected to the I/O module's CC-Link terminals. Refer to the *In-Sight<sup>®</sup> CIO-MICRO and CIO-MICRO-CC I/O Modules Installation Manual* for CC-Link network wiring examples.
- b. Use a screwdriver to loosen the appropriate screw terminals.
- c. Insert the CC-Link wires (using a CC-Link specified cable) to the CC-Link terminals and the other end of the cables to the applicable CC-Link devices.
- d. To reduce emissions, attach a Steward 28A0640-0A2 ferrite around the CC-Link wire bundle, as close to the connector as possible.



**Note:** The CC-Link network is daisy-chained and requires a terminal resistor for the first and last devices in the chain. Make certain that your connections are correct. Refer to the CC-Link website for more information and specification details.

- e. Tighten the screw terminals with the screwdriver to secure the wire leads in the terminal block; the maximum torque is 0.1921 Nm (1.7 in-lb).
5. Optionally, connect the I/O module to a serial device.
  - a. Plug an RS-232 serial cable (DB9 connector) into the I/O module's RS-232 OUT port.
  - b. Tighten the connector screws to secure it to the I/O module.
  - c. Connect the other end of the RS-232 serial cable to the serial device.
6. Connect to an Ethernet network.
  - a. Plug a LAN cable (RJ-45 connector) into the I/O module's LAN port.
  - b. Connect the other end of the LAN cable to a switch/router or PC, as applicable.
7. Connect the vision system's Ethernet cable.
  - a. Plug the Ethernet cable's keyed M12 connector into the vision system's ENET connector.
  - b. Plug the Ethernet cable's RJ-45 connector into the I/O module's PoE port.

**CAUTION:** The I/O module's PoE port provides Ethernet connectivity to the vision system. Connecting third-party devices to the I/O module's PoE port could damage the I/O module.

8. Connect the vision system's Power and I/O Breakout cable.

**Note:** Unused bare wires can be clipped short or tied back using a tie made of non-conductive material. Keep all bare wires separated from the +24VDC wire.

- a. Verify that the vision system's 24VDC power supply is unplugged and not receiving power.
- b. Optionally connect the I/O wires to an appropriate device (for example, a PLC). Refer to [Power and I/O Breakout Cable Specifications on page 22](#) for wiring details.
- c. Attach the Power and I/O Breakout cable's +24VDC (Red wire) and GROUND (Black wire) to the corresponding terminals on the power supply. Refer to [Power and I/O Breakout Cable Specifications on page 22](#) for wiring details.

**CAUTION:** Never connect voltages other than 24VDC. Always observe the polarity shown.

- d. Connect the Power and I/O Breakout cable's M12 connector to the vision system's PWR connector.
  - e. Restore power to the vision system's 24VDC power supply and turn it on if necessary.
9. Restore power to the I/O module's 24VDC power supply and turn it on if necessary.







P/N 597-0138-01 Rev. C  
Printed in the USA