

BOXER™

INDOOR ROBOTIC PLATFORM

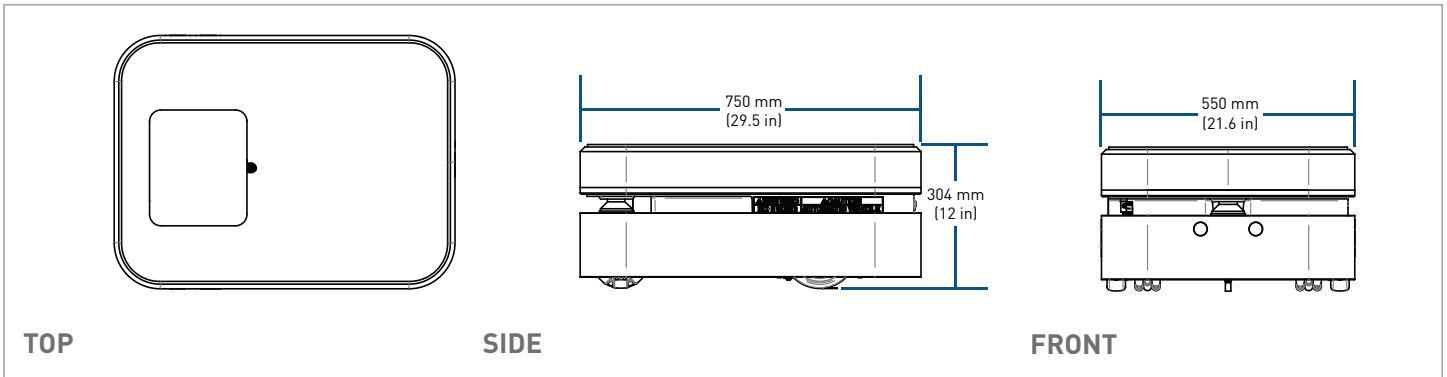

SIZE AND WEIGHT

EXTERNAL DIMENSIONS (L x W x H)	750 x 550 x 304 mm (29.5 x 21.6 x 12 in)
WEIGHT	127 kg (280 lbs)

SPEED AND PERFORMANCE

PAYLOAD	100 kg (220 lbs)
MAX SPEED	2.0 m/s (4.47 mph)
MAX ACCELERATION	1.0 m/s ²
INTEGRATED LIFT	50 mm (2") Stroke, 100 kg capacity
TURNING RADIUS	0 mm
MAX GRADE	1% / 0.5°
DRIVE CONFIGURATION / ENVIRONMENT	Differential Drive / Indoor
OPERATING TEMPERATURE RANGE	0°C to 40°C (32°F to 104°F)

BATTERY AND POWER SYSTEM

BATTERY CHEMISTRY	Lithium-ion
CAPACITY	60 Ah 24 V Nominal
POWER SUPPLY	12V & 24V @ 10A
RUNTIME	12 hr
CHARGE TIME	4 hr

INTERFACING AND COMMUNICATION

CUSTOM INTERFACING	3x Ethernet, 2x USB 3.0, E-Stop Extension, 12V Regulated Power (up to 10A), 24V Regulated Power (up to 10A), Unregulated Battery Power (up to 10A), LED Light Control Interface
WIFI	802.11 ac/a/b/g/n, 2.4 Ghz, 5 Ghz
SENSORS	Primary LIDAR 10m Range 260° FOV, Forward Stereo Camera System, Rear Facing Sonar, Odometry
DRIVERS/APIs	ROS, Gazebo, LED Light Control, RViz & URDF Support
INTERFACE	Emergency Stop Buttons, 360° RGB LED Array,
OPTIONAL ACCESSORIES	Manipulators, Grippers, Cameras, Stereo Cameras, IMU, 2D Laser Rangefinders, 3D Laser Rangefinders

CONTACT US FOR MORE INFORMATION

Clearpath Robotics Inc.
 1425 Strasburg Road,
 Kitchener, Ontario
 N2R 1H2, Canada

TEL: 1-800-301-3863
FAX: 1-888-374-0091
 @: info@clearpathrobotics.com
 web: www.clearpathrobotics.com

Don't forget to find us online:

