

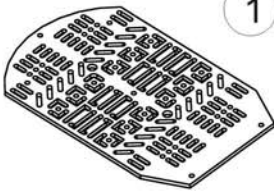

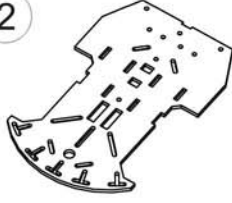



Magician chassis--DG007

Part list :

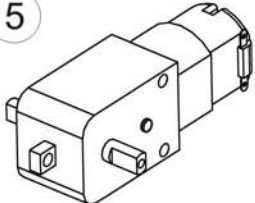
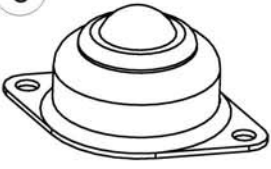
 <p>1 Chassis-up 1PC</p>	 <p>2 Chassis-bottom 1PC</p>	 <p>3 Motor holder 4PCS</p>	 <p>4 Speed board holder 2PCS</p>	 <p>5 Motor 2PCS</p>
 <p>6 Omni wheel 1PC</p>	 <p>7 Wheel 2PCS</p>	 <p>8 Battery holder 1PC</p>	 <p>9 L25 spacer 8PCS</p>	 <p>10 L10 spacer 4PCS</p>
 <p>11 M3*30 screw 4PCS</p>	 <p>12 M3*10 flathead screw 2PCS</p>	 <p>13 M3*6 screw 22PCS</p>	 <p>14 M3 nut 2PCS</p>	

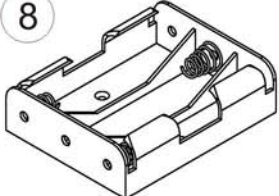
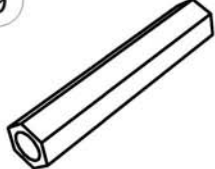
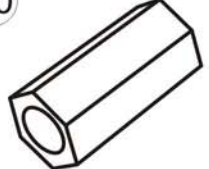
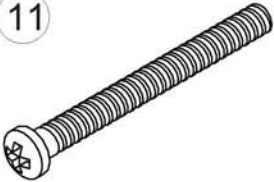
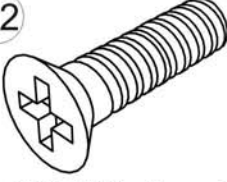
Assembly instruction :

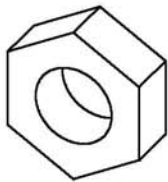
Step 1: insert motor holder as below drawing

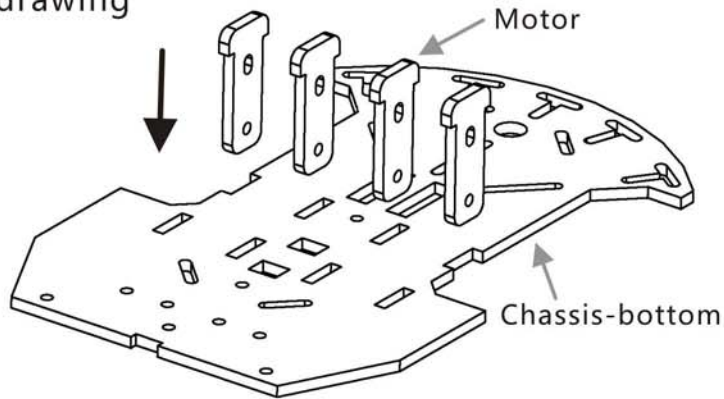

Step 2: assembly the motors as below drawing

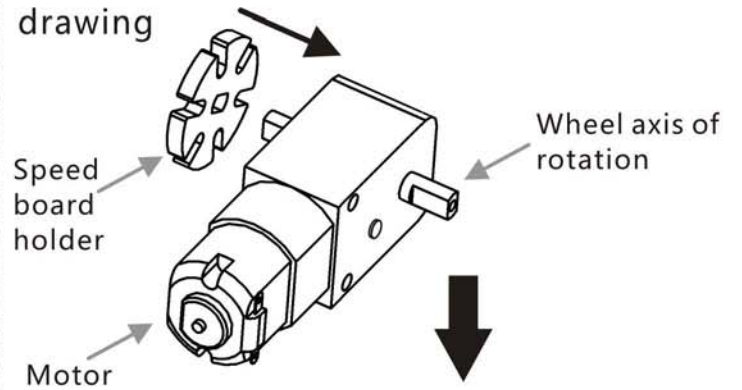

Step 3: screw the motors

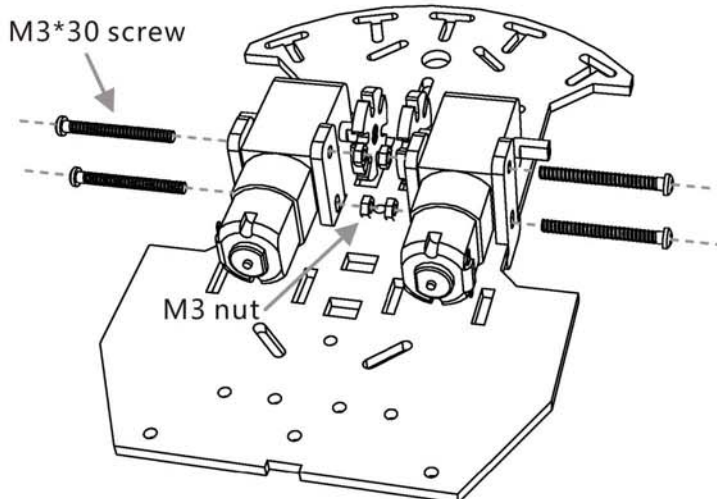

Side view

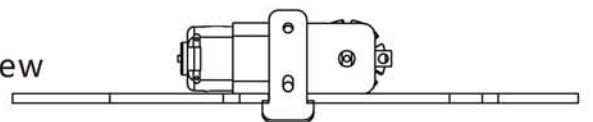

Step 4: assembly wheels

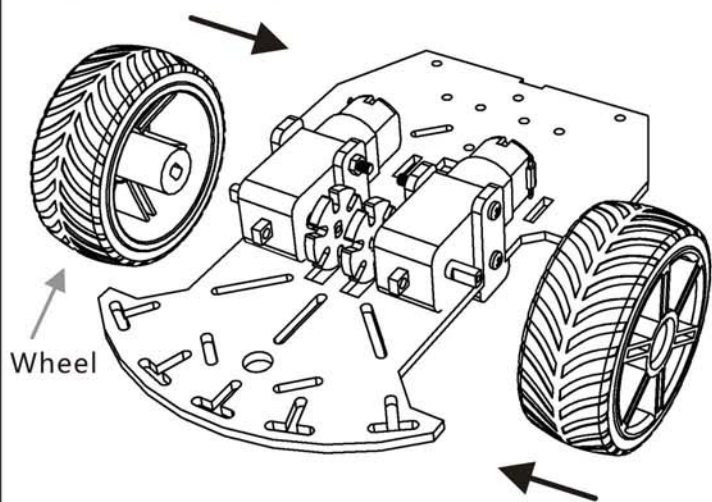

Step 5: assembly Omni wheel

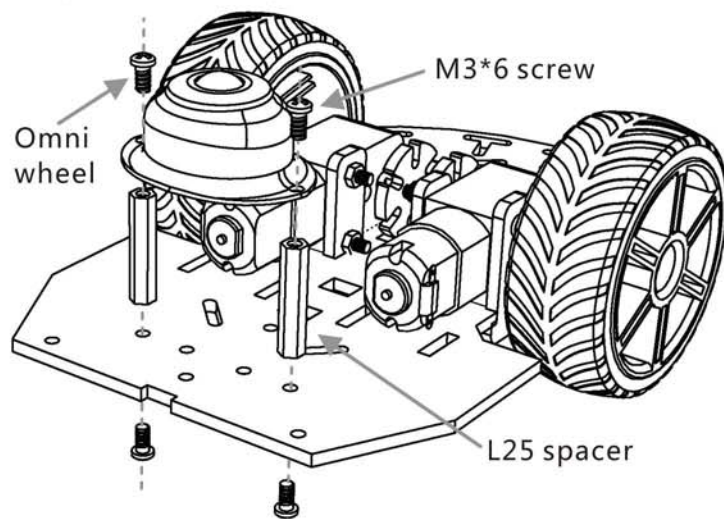

Step 6: assembly battery holder

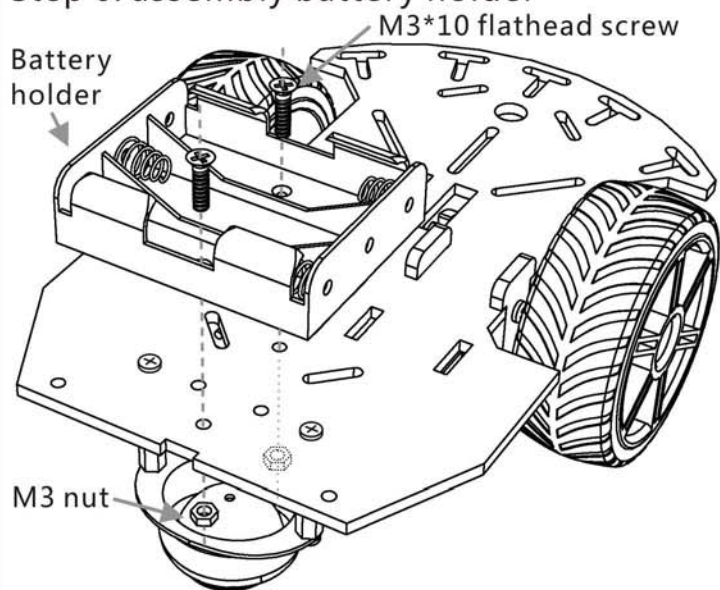

Step 7: assembly spacers

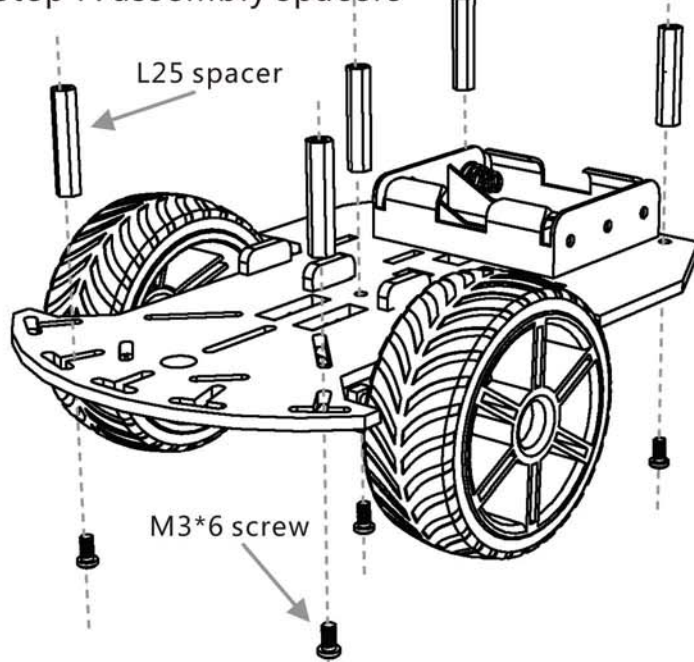

Step 8: assembly chassis-up

