

Multi Chassis Tank (rescue platform)

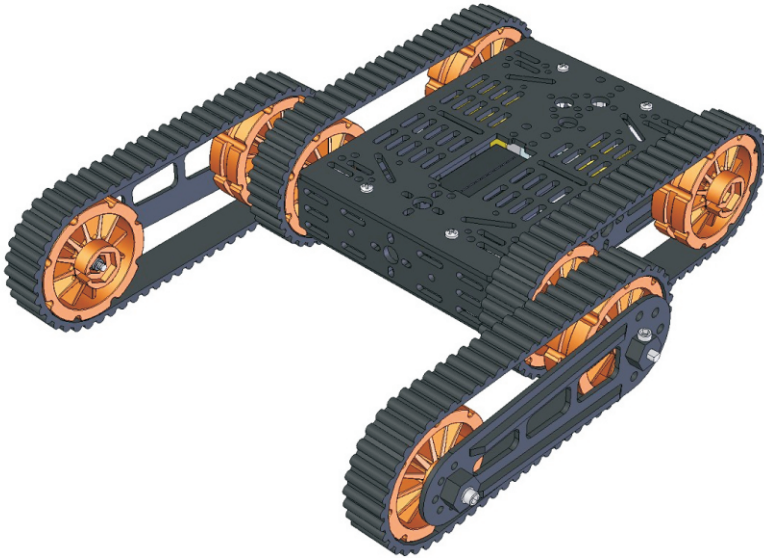

Copyright © 2013 by DAGU Hi-tech Electronic Co., Ltd.

All rights reserved. No portion of this instruction sheet or any artwork contained here in may be reproduced in any shape or form without the express written consent of DAGU Hi-tech Electronic Co., Ltd.

The manufacturer and distributor cannot be held responsible for any damages occurred by mishandling, mounting mistakes or misuse due to non-respect of the instructions contained in this manual.



Manufacturer:
DAGU Hi-Tech Electronic Co.,LTD
WWW.AREXX.COM.CN

Address:NO.4-107/108 HengXing Street, HengHai Rd, South District, ZhongShan
City of GuangDong China

TEL:0760-88811951

<http://www.arexx.com.cn>

E-mail:info@arexx.com.cn

Parts list:

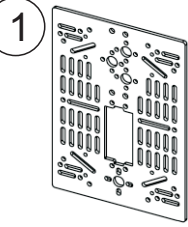

Aluminum chassis top 1pc

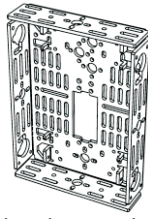

Aluminum chassis bottom 1pc

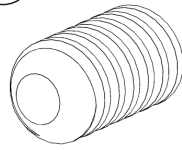

$\Phi 4$ kimi screw 2pcs

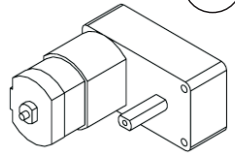

DC motor 2pcs

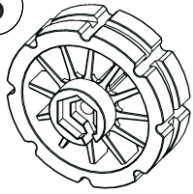

Track wheel 8pcs

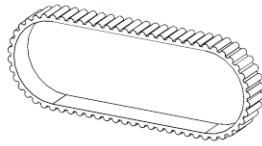

Rubber belt 4pcs

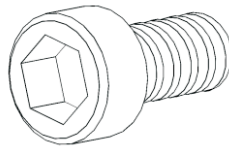

M3*6 hex screw 2pcs

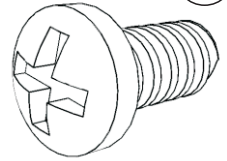

M3*8 round head screw 8pcs



$\Phi 3$ hex 1pc
 $\Phi 4$ hex 1pc

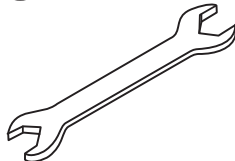

spanner (M2.5 & M4) 1pc

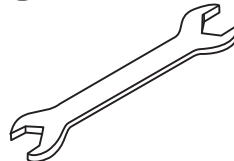

spanner (M2 & M3) 1pc

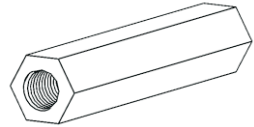

Distance holder M3*25 4pcs

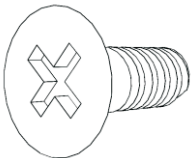

M3*8 flat-head screw 8pcs



M3*35 screw 2pcs

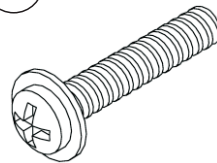

M3*16 screw with flange 2pcs

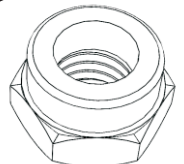

M3 nyloc nut 2pcs

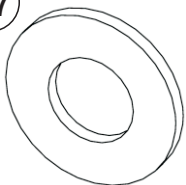

M3 washer (thin) 10pcs

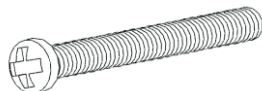



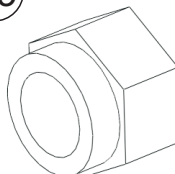

M2.5*25 screw 2pcs

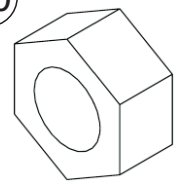

M2.5 nyloc screw 4pcs

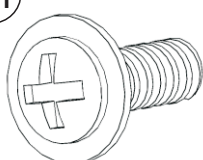
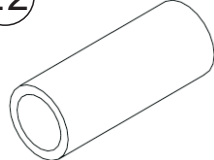
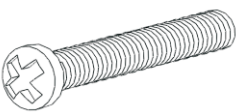
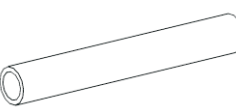
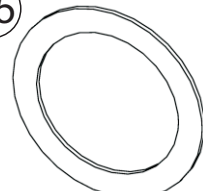
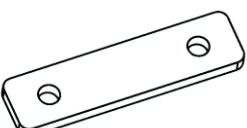
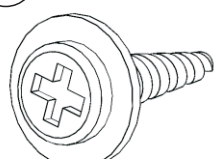
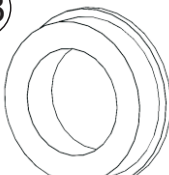
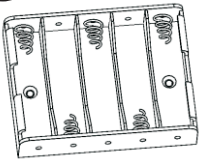
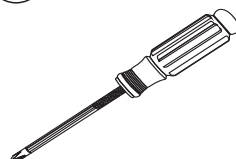
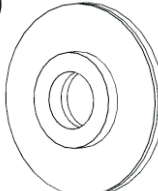
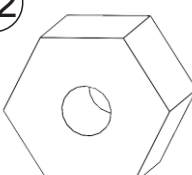
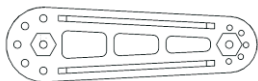

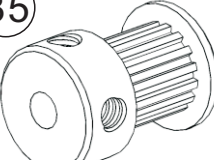
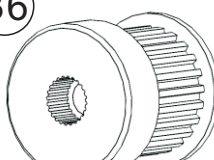
M3 nut 4pcs

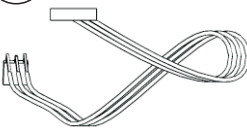
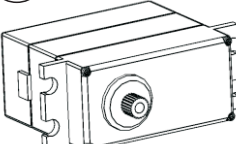
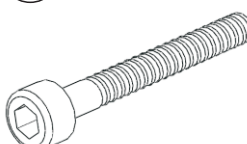
<p>21</p>  <p>M3*8 screw with flange 4pcs</p>	<p>22</p>  <p>Φ3*10 spacer 2pcs</p>	<p>23</p>  <p>M2.5*20 screw 2pcs</p>	<p>24</p>  <p>Φ3*28 spacer 2pcs</p>
<p>25</p>  <p>15*20*1 washer 4pcs</p>	<p>26</p>  <p>Hall sensor holder 2pcs</p>	<p>27</p>  <p>M2.3*8 tapping screw with flange 6pcs</p>	<p>28</p>  <p>10*15*4 flange bearings 4pcs</p>
<p>29</p>  <p>5XAA battery holder 1pc</p>	<p>30</p>  <p>Screw driver 1pc</p>	<p>31</p>  <p>Hall sensor encoder kit 2pcs</p>	<p>32</p>  <p>Φ4 Hexagonal connecting piece 2pcs</p>
<p>33</p>  <p>Delicate aluminum bracket 2pcs</p>	<p>34</p>  <p>Long axle 1pc</p>	<p>35</p>  <p>Φ4 16T synchronizing gear 1pc</p>	<p>36</p>  <p>Φ4 24T synchronizing gear 1pc</p>
<p>37</p>  <p>60MXL synchronizing belt 1pc</p>	<p>38</p>  <p>Hall sensor 2pcs</p>	<p>39</p>  <p>13kgs servo 1pc</p>	<p>40</p>  <p>M3*22 screw 1pc</p>

41

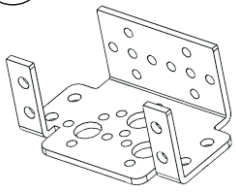

U shape holder 1pc

42

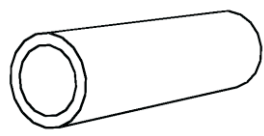

Φ3*12 spacer 1pc

Assembly Instructions:

Step 1:

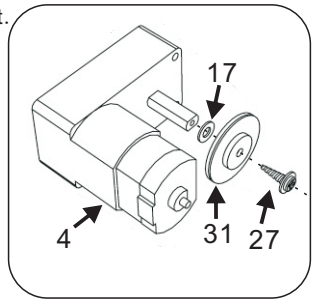
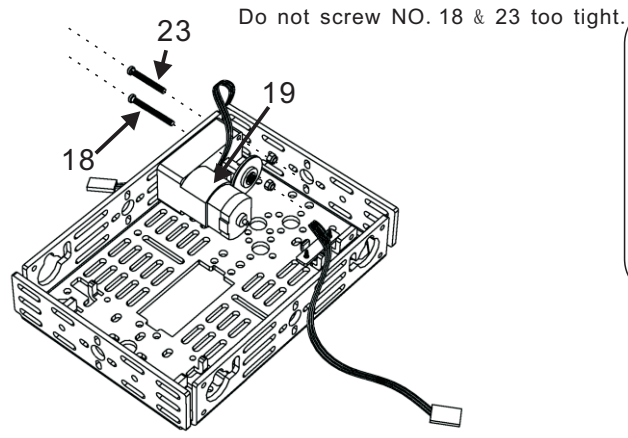

We suggest to bend the hall sensor to 6~8mm height
Please assembly the hall sensor with a marking "20L"
facing towards the magnet.

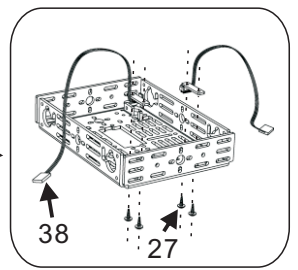

Step 2:

Use the ruler to check the length of your screws .

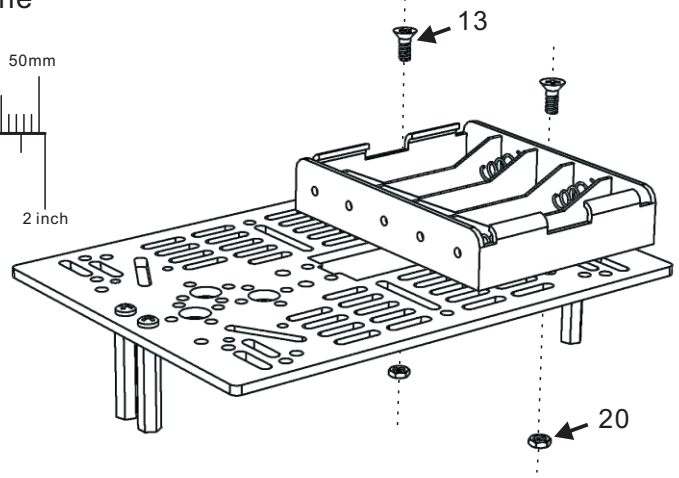
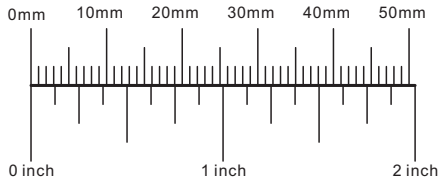

Step 3:

Due to the wheel and metal shaft matching too tight and try to avoid scratch the wheel hub, we suggest to apply some lubricate on the metal shaft.

Reminder: if the wheel assembly too tight, it makes the DC motor turn hard, please get the NO. 15 screw out and put screw M3*15 instead, hold the wheel in hand, and use a hammer to push M3*15 into the wheel hub, then it becomes easy to pull out the wheel. Next is to reassembly wheel again according to the steps.

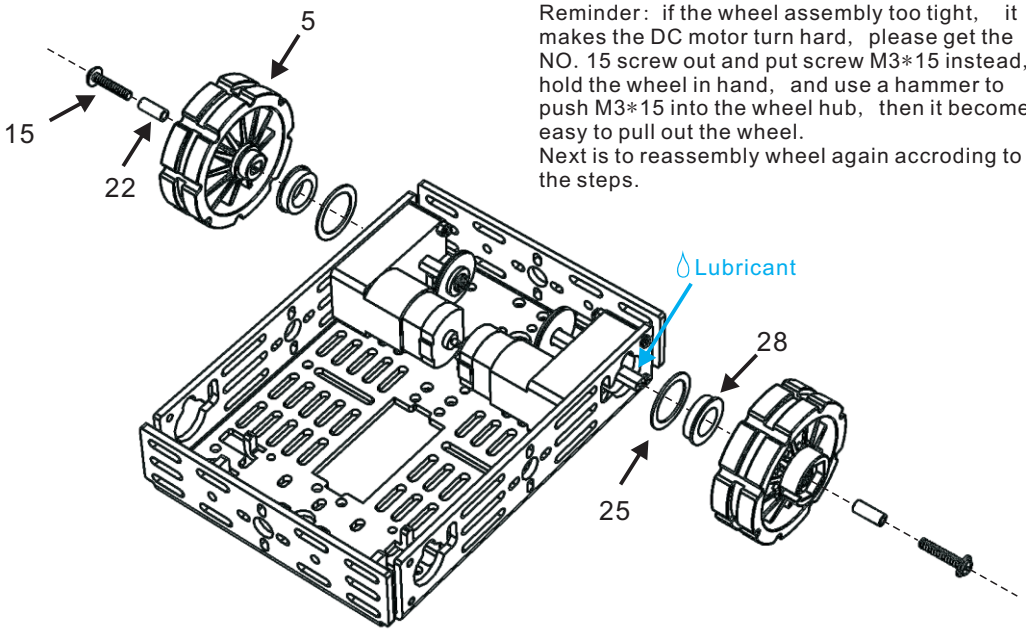

Step 4:

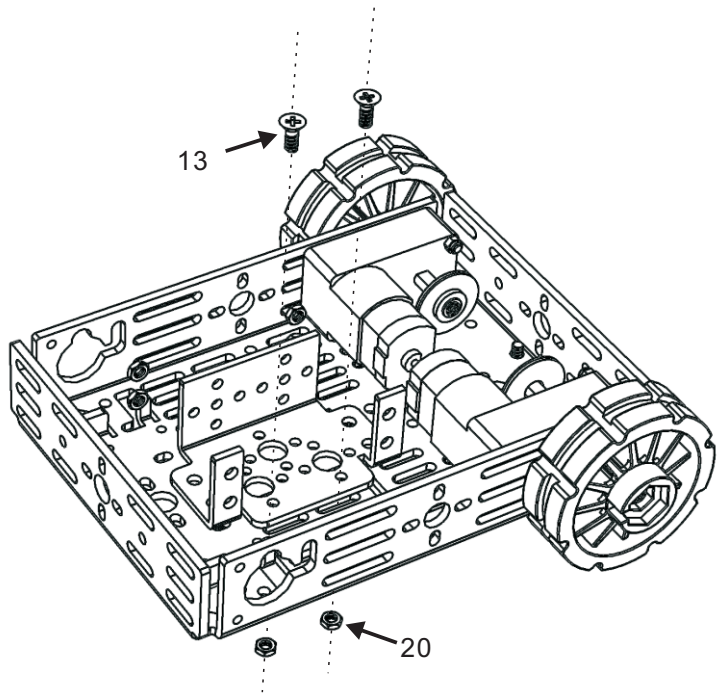

Step 5:

Use the ruler to check the length of your screws .

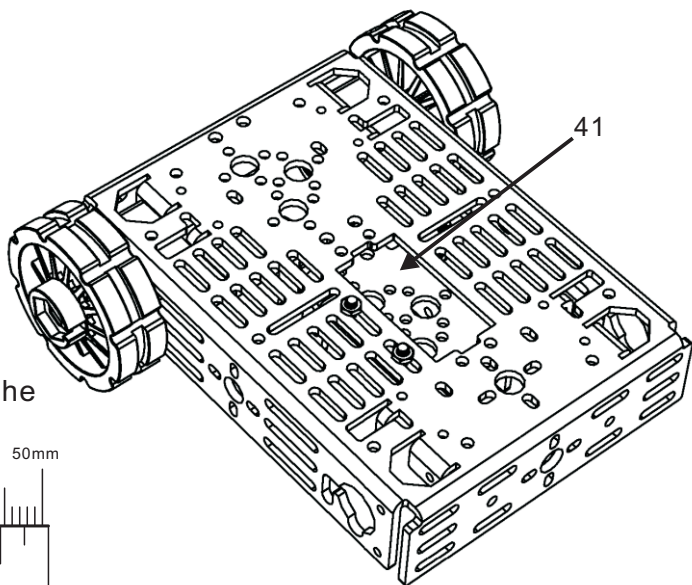
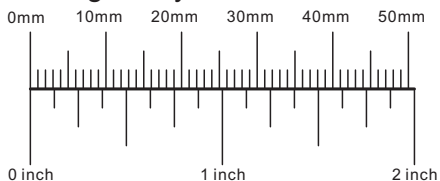

Step 6:

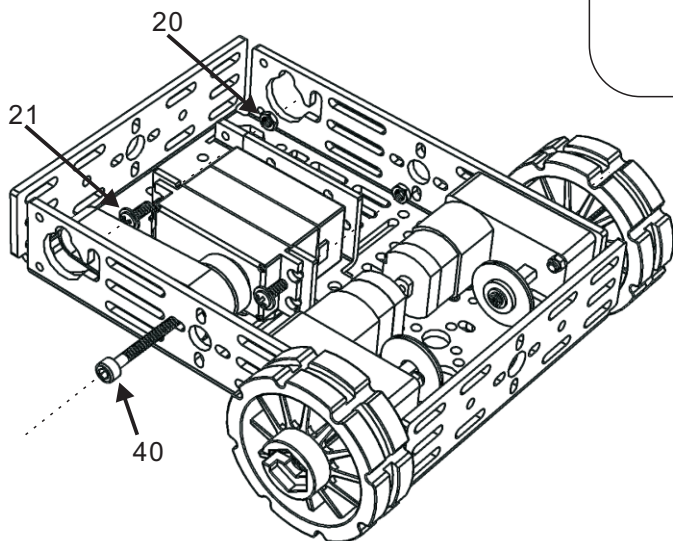
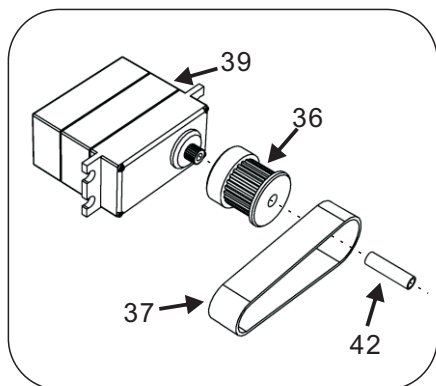

Step 7:

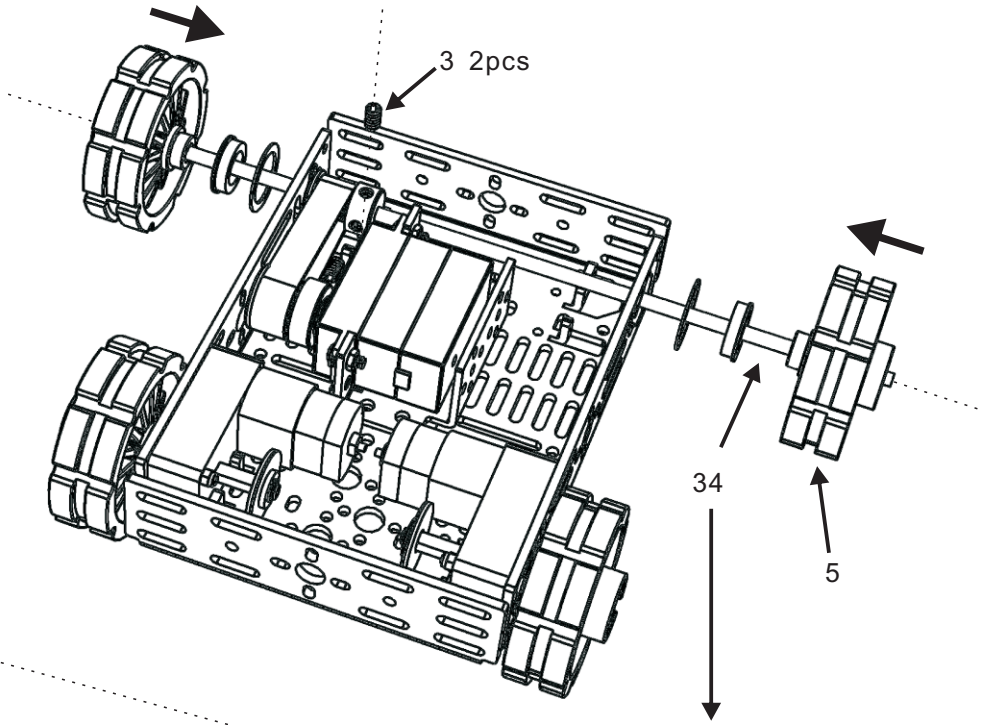

Step 8:

Ensure that the wheel turn smoothly, apply some lubricate in the wheel hub.

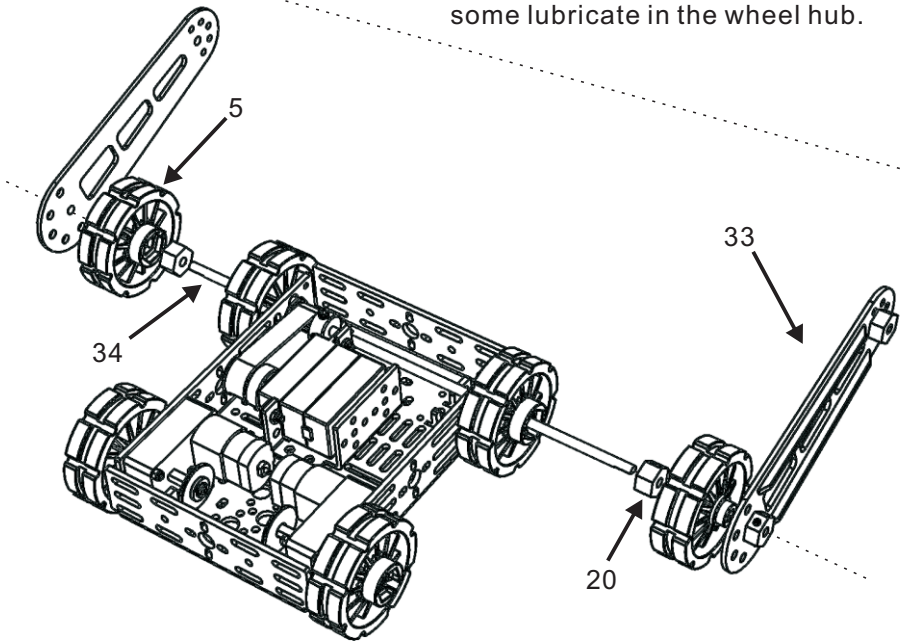

Step 9:

Ensure that the wheel turn smoothly, do not screw the NO.16 too tight. And NO.24 should apply some lubricate.

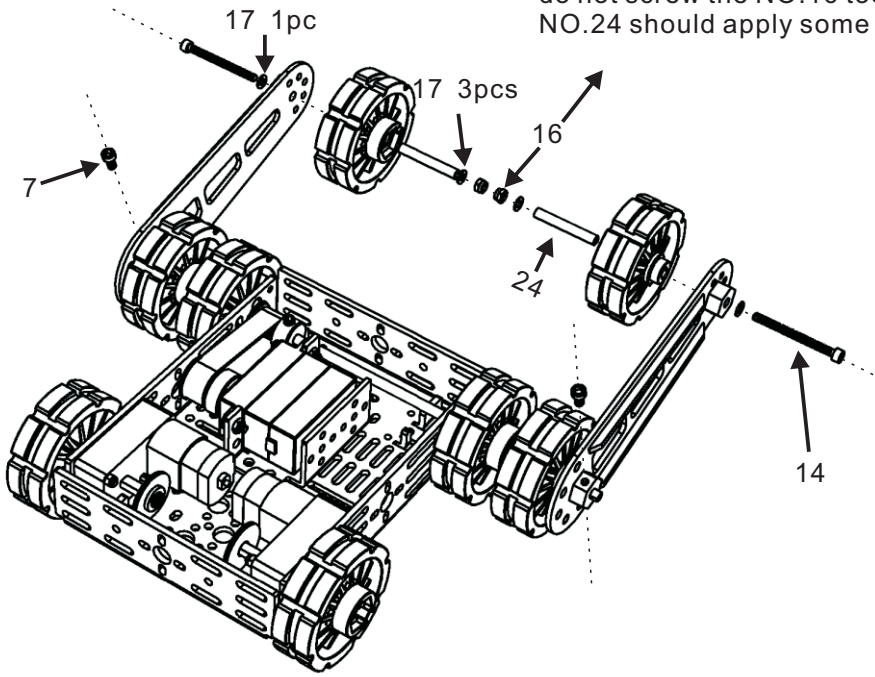

Step 10:

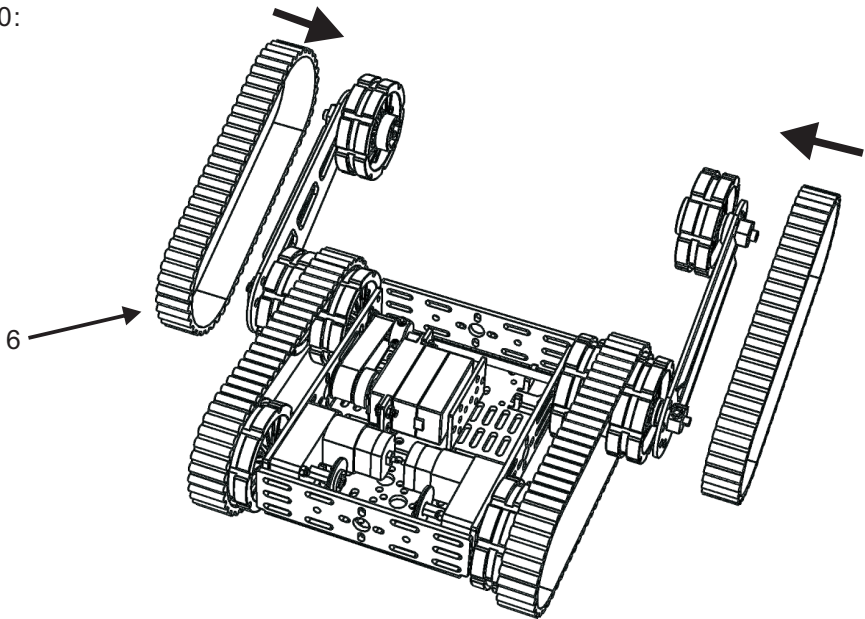

Step 11:

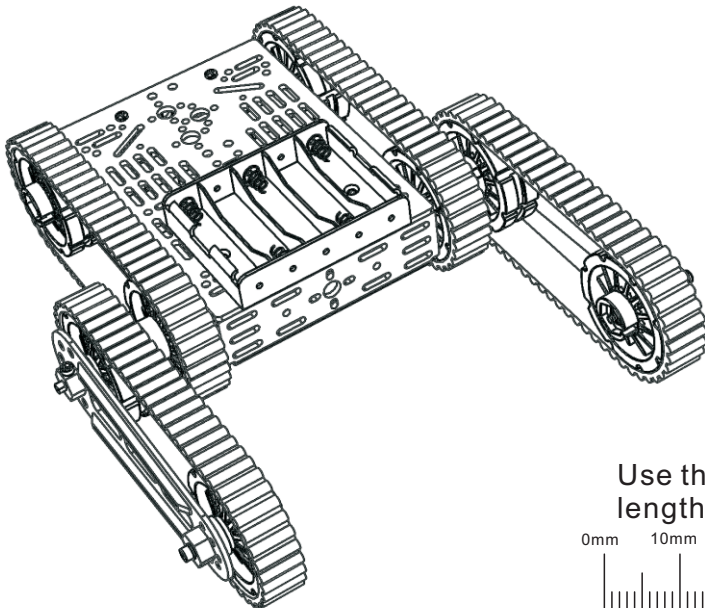
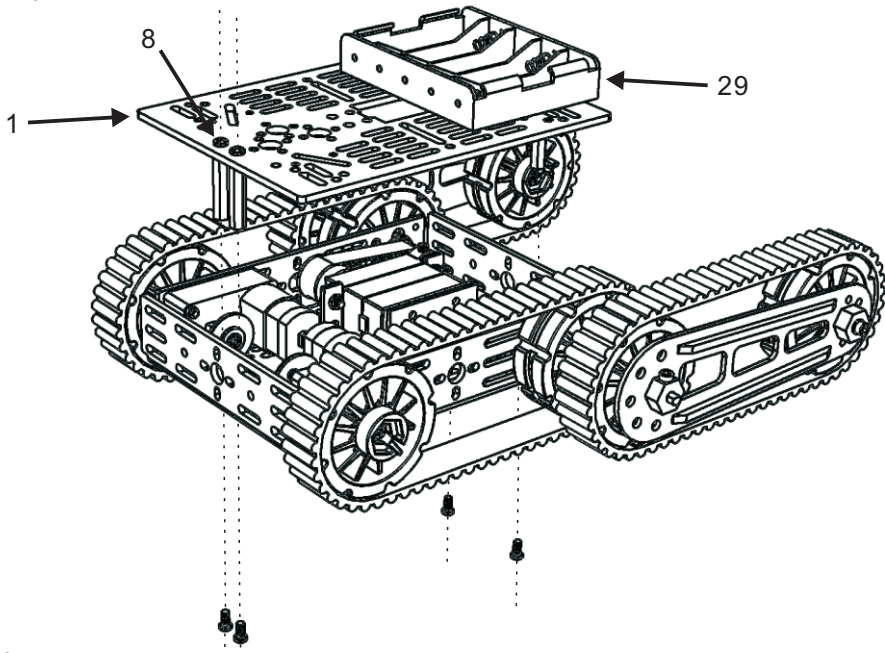

Use the ruler to check the length of your screws .

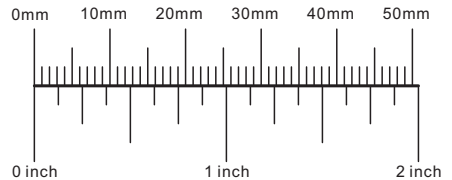

Finished