

PHANTOMX REACTOR

Visit the PhantomX Reactor Product Page

EXTREMELY RIGID
BOXED ABS DESIGN

OPTIONAL
WRIST ROTATE

MOUNTING BRACKETS
FOR CAMERA & SENSORS

PARALLEL
GRIPPER

DUAL SERVO DESIGN
SHOULDER & ELBOW

INDUSTRY LEADING
AX-12A SERVOS

SOLID 14CM DIAMETER
BALL BEARING BASE



ARBOTIX MICROCONTROLLER

- ATMEGA ATMEGA 644P
- DIGITAL & ANALOG I/O
- ROS READY
- XBEE WIRELESS
- ARDUINO IDE
- CUSTOM FIRMWARE

STATS

WEIGHT: 1360G (1430 W/ ROTATE)
VERT REACH: 51CM (55.5 W/ROTATE)
HORZ REACH: 40CM (44 W/ROTATE)
STRENGTH: 30CM/200G
(NO ROTATE) 20CM/400G
10CM/600G
GRIPPER: 500G HOLDING STRENGTH
WRIST LIFT: 250G (150 W/ROTATE)

The PhantomX Reactor Robot Arm is the first in Interbotix Labs' offering of Arbotix based research grade robotic arms. The Reactor Arm was designed with reach and agility in mind, but it still boasts considerable strength for an arm of its size.

The PhantomX Reactor Robot Arm was designed with entry-level research and university use in mind, providing one of the highest featured arms on the market today while not breaking one's budget.

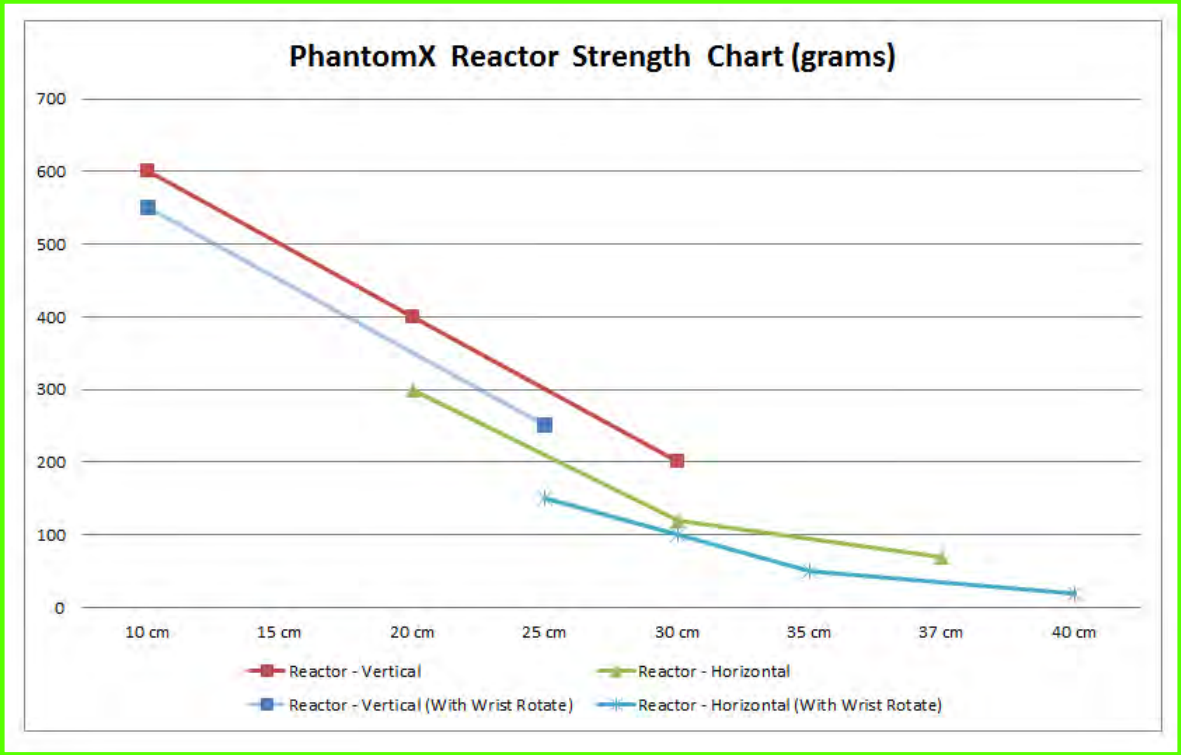

The Reactor Robot Arm has up to a 43cm horizontal reach and 55cm of vertical reach. At a 10cm reach it can lift up to 600g, and at 30cm up to 200g. The gripper itself has a rated holding strength of up to 500g, while the wrist itself can lift up to 250g horizontally. (150g if using wrist rotate).

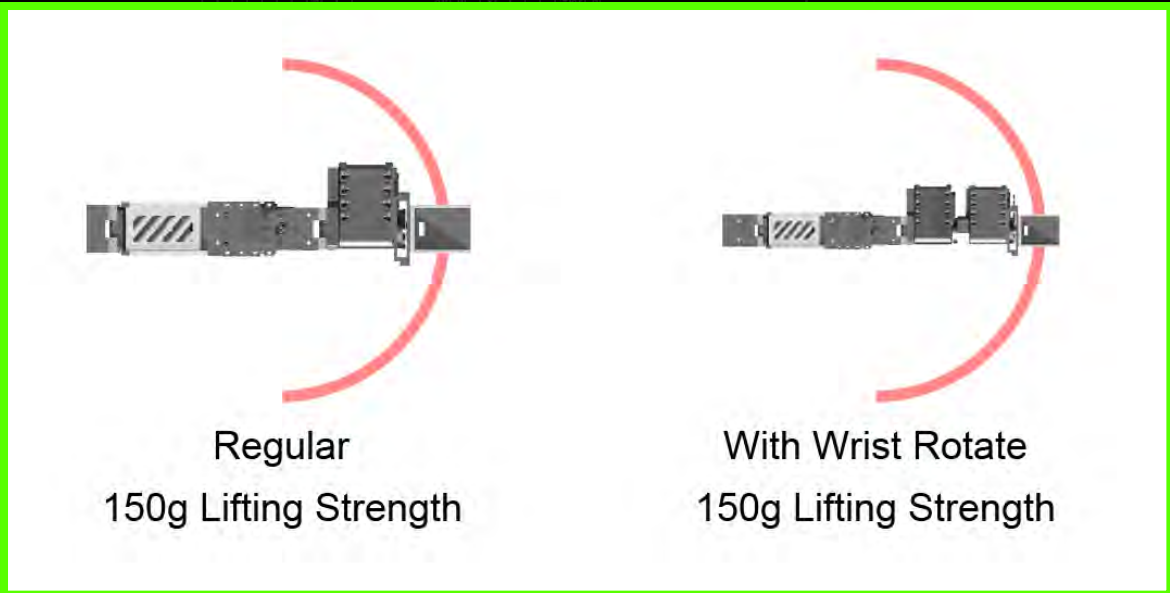

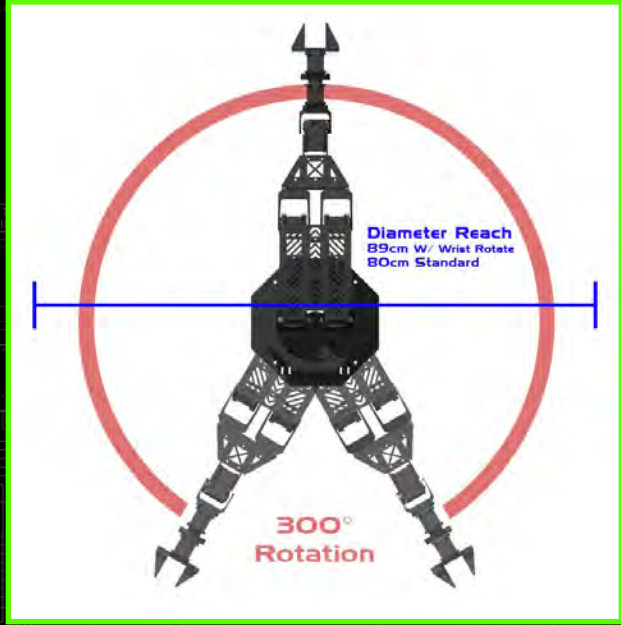
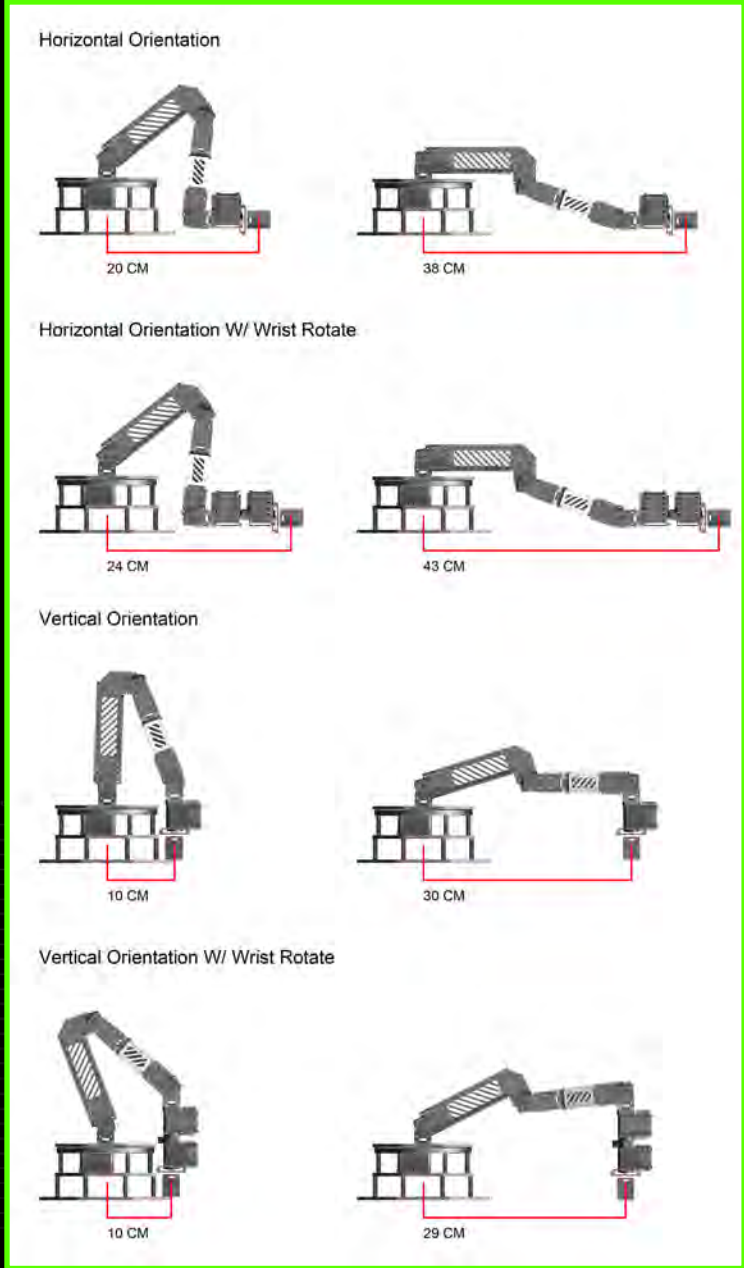

Dynamixels support up to 300 degrees of motion, which results in an extraordinary range of motion and reach on the PhantomX Reactor. Temperature monitoring, positional feedback, as well as voltage levels, load, and compliance settings are user accessible as well.

A rugged ABS boxed frame design and 14cm diameter ball bearing rotational base ensures maximum rigidity and accuracy. Optional wrist rotate allows for up to 5 degrees of freedom, along with a custom designed parallel gripper for high precision and maximum gripping strength.



SM-83

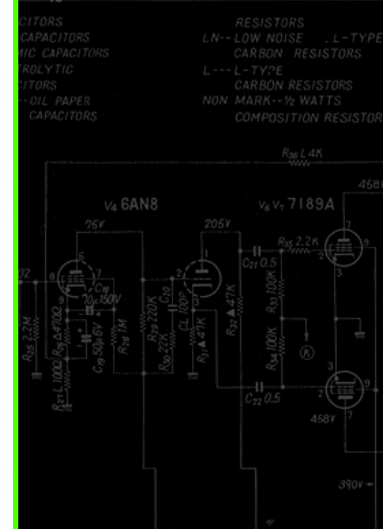
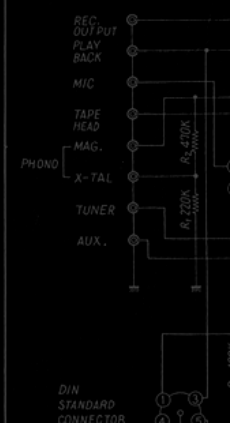

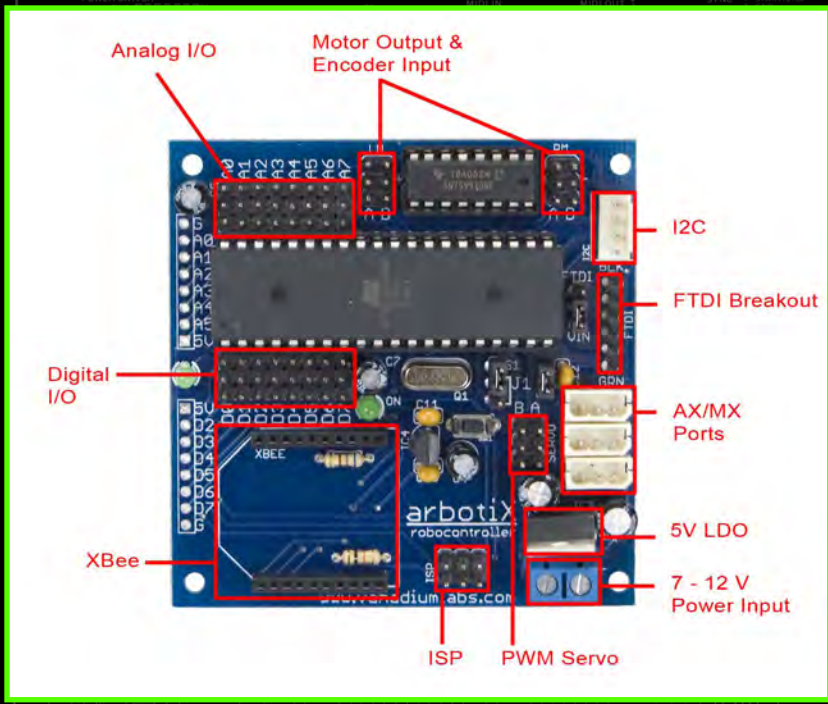

The onboard Arbotix Robocontroller can be programmed using the Arduino IDE or custom firmware, providing 8 digital and analog IOs, Xbee wireless or USB connectivity, and a powerful ATmega644p capable of handling Inverse Kinematics code onboard.

- ATmega644p Microprocessor
- 8 Analog & 8 Digital IOs
- Physical, Xbee Wireless, & USB/TTL Serial control options
- Arduino IDE compatible
- Custom firmware capable
- ROS Ready

The PhantomX Reactor Has Many Control Options...

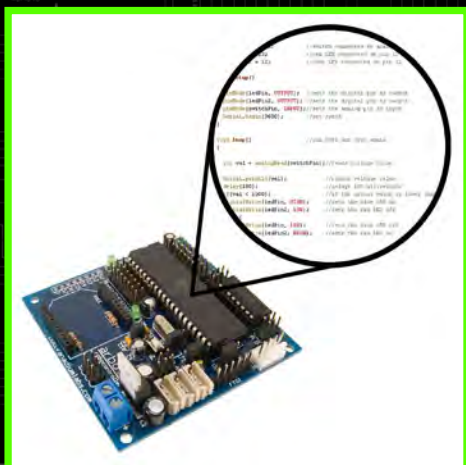

Onboard code / autonomous programming



Computer tethered USB TTL



Wireless Xbee



Direct drive via controls

[Visit the PhantomX Reactor Product Page](#)