

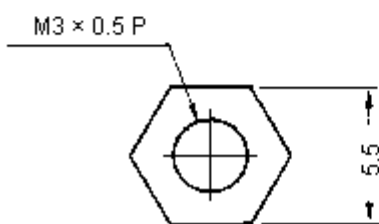

Features:

- Material designation : 101 (+) (f1), 101F (+) (f1), 101L (+) (f1), E101 (+) (f1), E101L (f1), 132F (+) (f1), 135F (+) (f1)
- Product description : Polyamide 66 (PA66), designated "zytel" furnished as pellets
- Dielectric strength : 13 kV / mm
- Volume resistivity : 14 ($10^k \Omega\text{-cm}$)
- CTI : 0
- HVTR : 0
- D495 : 6

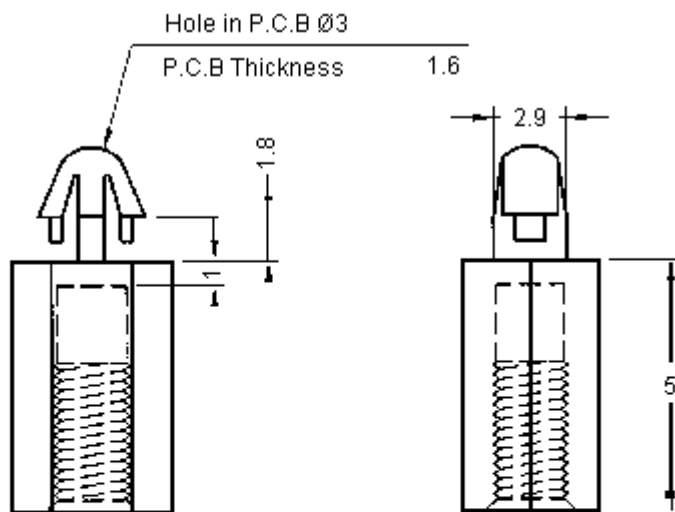

Dimensions : Millimetres

Specification Table

Colour	Minimum Thickness (mm)	Flame Class	HWI	HAI	RTI Elec	RTI Imp	RTI Str	IEC GWIT	IEC GWFI
All	0.71	V-2	4	0	130	75	85	725	960
	1.5		3					750	
	3		2					800	
	6								

(+) Virgin and regrind up to 50% by weight inclusive, have the same basic material characteristics

(f1) Suitable for outdoor use with respect to exposure to ultraviolet light, water exposure and immersion in accordance with UL 746C

Part Number Table

Description	Part Number
PCB Spacer Support, Nylon66, Natural	D01463
PCB Spacer Support, Nylon66, Natural	D01467
PCB Spacer Support, Nylon66, Natural	D01468

Important Notice : This data sheet and its contents (the "Information") belong to the members of the Premier Farnell group of companies (the "Group") or are licensed to it. No licence is granted for the use of it other than for information purposes in connection with the products to which it relates. No licence of any intellectual property rights is granted. The Information is subject to change without notice and replaces all data sheets previously supplied. The Information supplied is believed to be accurate but the Group assumes no responsibility for its accuracy or completeness, any error in or omission from it or for any use made of it. Users of this data sheet should check for themselves the Information and the suitability of the products for their purpose and not make any assumptions based on information included or omitted. Liability for loss or damage resulting from any reliance on the Information or use of it (including liability resulting from negligence or where the Group was aware of the possibility of such loss or damage arising) is excluded. This will not operate to limit or restrict the Group's liability for death or personal injury resulting from its negligence. DURATOOL is the registered trademark of the Group. © Premier Farnell plc 2012.