

4

3

2

1

F

F

E

E

D

D

C

C

B

B

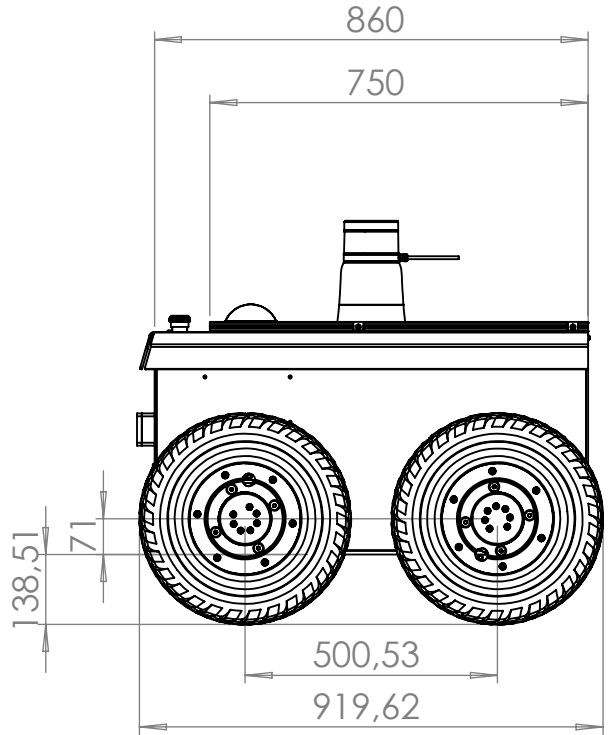
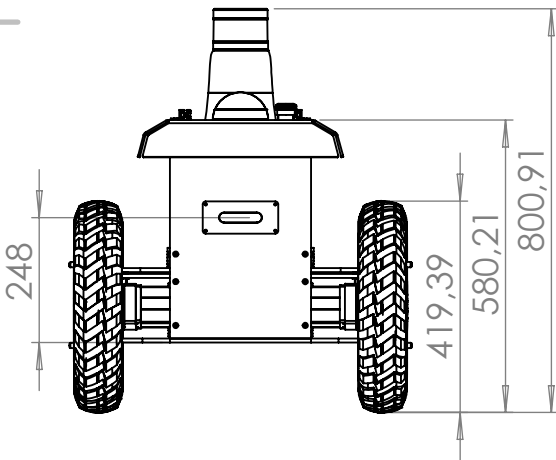
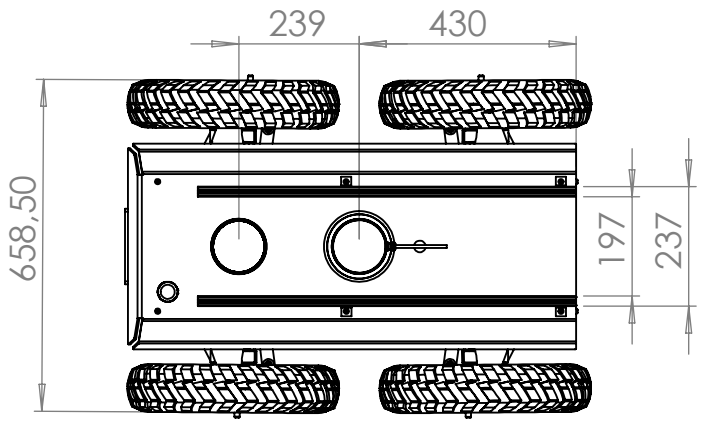

Remarques :

TITRE:

Plan_technique_RR100

A

A

NOM	SIGNATURE	DATE	MATERIAU:
AUTEUR		06/11/2020	
VERIF.			
FAB.			MASSE:

No. DE PLAN	A4
ECHELLE:1:15	Feuille 1 sur 1

4

3

2

1