

**The following information
are used to understand
hardware structure of Go1
and the functions of all
parts.**

**Partly exaggerated, but
basically true.**

**You can send this
document to R&D client to
introduce Go1 series robot.**

Go 1

Go Wherever You Will Go

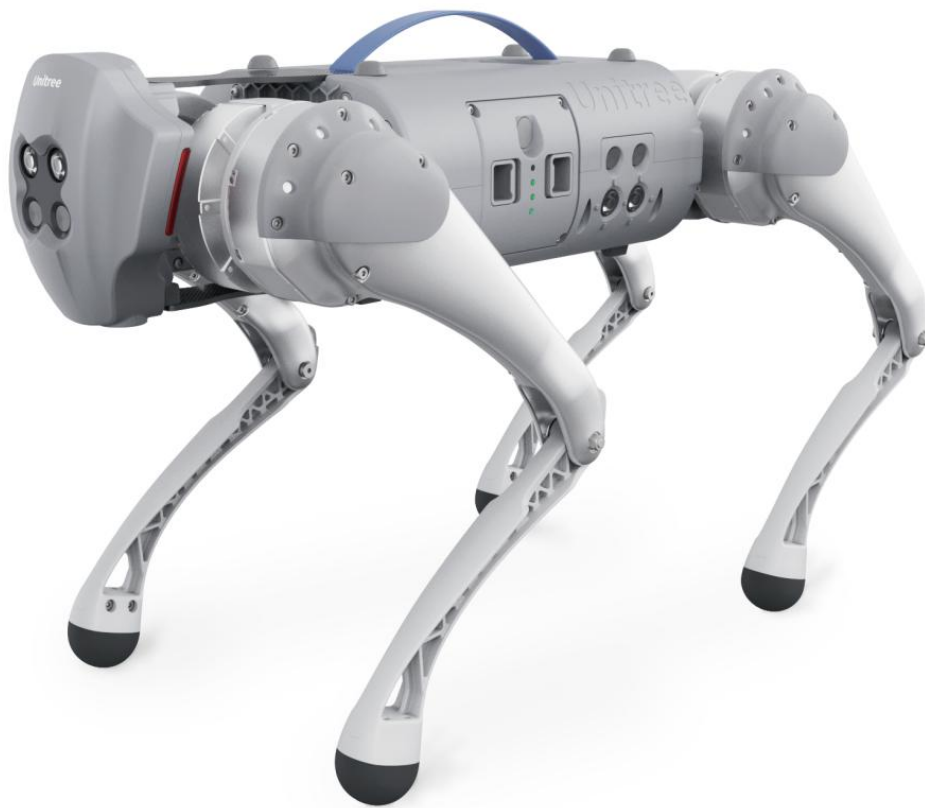

Unitree

Physical Characteristics

Basic information

Dimensions	LxWxH(Stand)	0.645*0.28*0.4m
	LxWxH(Folded)	0.54*0.29*0.13m
Machine	(with battery) 12 kg	
Load	5kg (EDU version) 3kg (other version)	
Maximum speed	3.7 m/s (Air version 2.5m/s)	
Operating time	1-2 h	
Maximum angle climb	35°	
DOF	Total 12, one leg 3	
Power Outputs	5V, 12V, 24V etc.	
Abundant External Interface	HDMI*3; Gigabit Ethernet port*1; USB*3; Integration Interface *1	
Protected Mode	Fall protection, overheat, emergency stop protection	
Warning	Low voltage, High temperature, Short circuit, overcharge	
Foot Force sensor	4 (only EDU)	
Control	Remote/slide-follow/autonomous	

Brain System

Main board

Controllers	Basic	Motion	×1
	Motion	×1, 4core@1.5GHz, memory DDR4L 2GB, flash memory 32GB	
	Sensory controller		×1 or ×3, Nano
Processor upgrade		EDU version machine support changing Nano to NX	
Heat-dissipating method		cooling fin +fan	

software

Real-time operating systems	Motion control: Ubuntu
	Environmental Perception: Ubuntu-ROS
Framework	ARM
Programming	C++or C, Python, Graphical programming

Connect

Network	GE/WiFi	4G or 5G
Data	USB	Integration Interface
Others	HDMI	Bluetooth transfer image

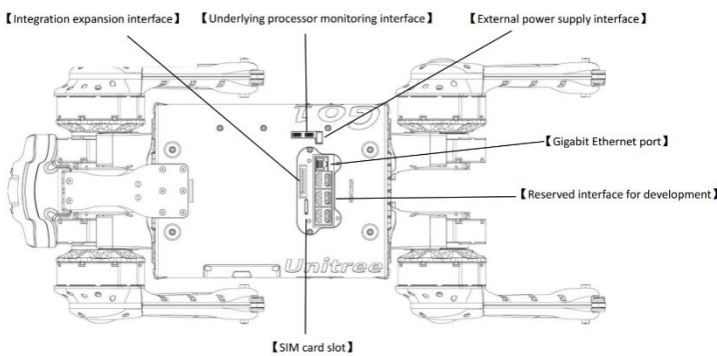
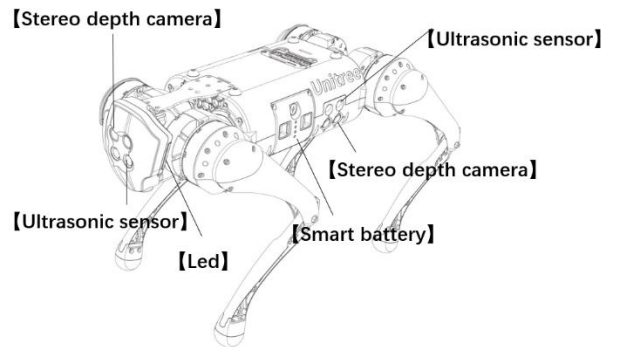
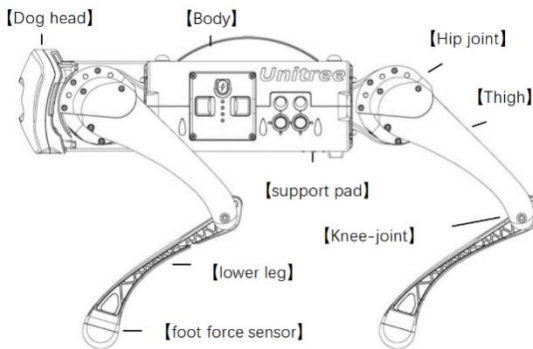

HUMEN-MACHINE interaction

Remote control handle

Type	Unitree Go1
Detachable rocker	2
Charging port	Type C
LED	Power display and charging status
Battery life	4 h

Smaller controller (UWB)

Angular positioning accuracy	$\pm 5^\circ$
Positioning distance	0.1-3m
Sampling rate	50 Hz
Control mode	rocker*1, button*4, antenna*1
Battery life	4h

Speaker

Sound track	left& right
Rated resistance	4 Ω
Diameter	23.7 mm
Scope of influence	380Hz-10KHz
Power rating	2 W
Sensitivity	82 DB
Quantity	1
secondary development	Support

Mobile phone APP

Virtual joystick buttons	Support
Image Retransmission	Wifi/4G/5G
Simulator	immersive robot dog simulator features
Function	RGB, depth map switch

Light

Secondary development	support
LED	64-color ambient light

Environmental sensor

Fish-eye Stereo Depth Cameras

Sets	5
Totally Units	10
Single depth camera lens angle	150*170
Fish-eye AI Perception	Human Recognition

Ultrasonic sensory

Mileage	5-200cm, 20-200cm (tail)
Measurement accuracy	$\pm (1+S*3\%)$
Temperature compensation	Support

Foot force sensor

Dimension	1
Quantity	4
Resolution ratio	5g

High precision laser radar

Radar type	2D lidar	3D lidar (16line)
Measuring distance	$\leq 40m$	Reach 100m
Operating voltage	5v	9-18V
Operating temperature range	$-5^\circ C \sim 45^\circ C$	$-10^\circ C \sim +60^\circ C$
Weight	165g	830g

Navigation planning, dynamic obstacle avoidance, autonomous positioning, map construction and other functions. Support secondary development

Inertial measurement unit (IMU)

Body IMU quantity	1
DOF	6
Dynamic accuracy	1°

User-friendly interface

- User PC could use ethernet to connect directly to the robot's built-in motion controller, sensory controller and underlying controller
- The robot base controller, robot on-board controller and user PC can communicate freely with each other to facilitate real-time transfer of visual perception and other data.
- Robot on-board sensors are fully open, available for secondary development
- Develop the underlying control: All motors and sensors of the robot can be read and controlled in real time, facilitating the direct use of open source robot algorithms
- Develop high-level control: could send high-level motion commands such as backward, forward, left, right and left movement directly to the robot

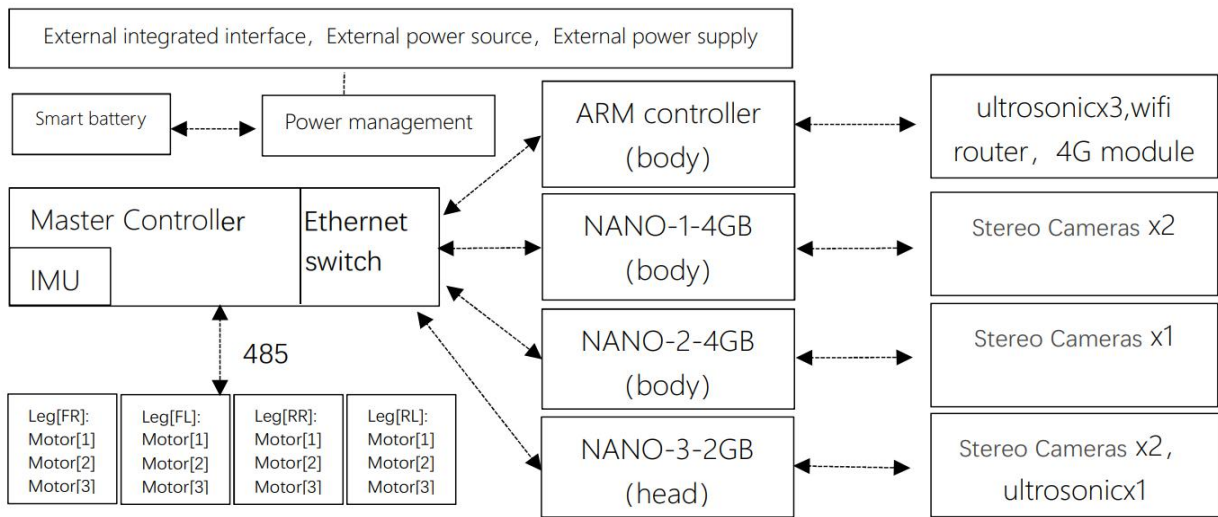

Unitree official Github link: github.com/unitreerobotics 3D model download/Simulation/Abundant Demo/ Forums

Break global speed record in same class



Powerful and reliable power system



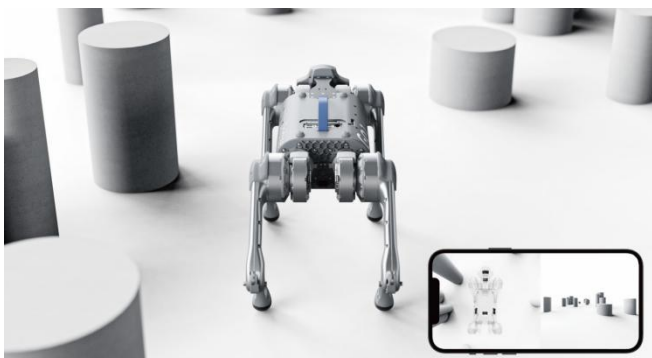

Intelligent Side-follow System

Adopt Patented Wireless Vector Positioning and Control Technology

- Robot walks alongside its human master, which is much better than the conventional following mode. Besides, the human-machine interaction is both harmonious and safe.
- No need to worry about the robot since it's right beside you.
- Capable of helping robot choosing better route in complex environment

Super Sensory System

Full View Coverage

- 5 Sets Fish-eye Stereo Depth Cameras + Ai Post-processing + 3 Sets Hypersonic Sensors
- 1 set fish-eye stereo Depth deception angle $\approx 150 \times 170^\circ$
- 1set fish-eye stereo depth perception ≈ 4 sets intel real sense perception angle
- So: 5 sets fish-eye stereo Depth perception ≈ 20 sets intel real sense perception angle
- Fish-eye AI perception: body recognition etc.

Go 1 built-in Powerful AI

16 core CPU+ GPU (384Core, 1.5TFLOPS)

- For comparison, the Nvidia TX2 only has CPU (4 cores) +GPU(256Core, 1.3TFlops)

Parameter

(I) Hardware platform

- weight (with battery) $12\text{kg} \pm 1.5\text{kg}$
- L*W*H $0.645*0.28*0.4\text{m}$
- Load capacity: 5kg
- Sufficient range of motion in all joints:
 - Lateral hip swing joint: $-40^{\circ} \sim +40^{\circ}$
 - Anterior hip swing joint: $-218^{\circ} \sim +45^{\circ}$
 - Knee joint: $+24^{\circ} \sim +132^{\circ}$
- Equip foot force sensor: provide foot force sensor feedback interface
- Equip HDMI*3; Gigabit Ethernet port*1;、USB*3;、2 TYPE-C、1 SIM card slot、1 back Integration Interface *1. Abundant Teaching and research development interface
- fastest running speed 3.7m/s
- Built-in super Ai (16 cores CPU+ GPU (384Core,1.5TFLOPS))
- Equipped with abdominal power interface, supporting the expansion of wireless or touch autonomy charging function
 - Legs and body connection with omnidirectional flexible cushioning structure, can absorb the impact from all around

(II) Motion control hardware and software

- built-in ARM controller : motion controller 4cores @1.5GHz。 memory DDR4L 2GB, flash memory 32GB
- fastest running speed 4.7m/s (world record)
- With jumping air turn 90° / tap dance / space step / double leg stand and other functions
 - Machine dog with good buffering function, owning the ability that to fall from a height of 1 meter without damage and to continue walking within 2 seconds

(III) Perception module

- Super Dynamic side-follow Autonomous Obstacle Avoidance System
- Built-in wireless vector positioning system
- Built-in 3 Nano controller
- Built-in 4 ultrasonic probe
- Built 5 Sets Fish-eye Stereo depth camera, Open 5 groups of fisheye binocular depth camera RGB map and

point cloud map. Single group camera perception angle about $150^{\circ} * 170^{\circ}$

- built-in 1 3W loudspeaker
- built-in 4G module(include GNSS) : 4G remote control/image transformation/shout-out, GPS/BeiDou data acquisition
- God's eye view, APP immersion robot dog simulator function

Support Events

- RoboCom (national games, A class event)
- World Robot Contest (national games, A class event)
- CHINA ROBOT COMPETITION (national games)
- International Youth AI Competition (national games)
- Various Education Department provincial competitions.